

# **PJ20301 Datasheet**

## **5.5V, 3A, Ultra Low Dropout And Low Iq LDO In DFN3x3-10 and PSOP-8 Package**

**Version: Rev.1.1**

Release Date: 2026-02-06

MetaWells Co., Ltd.

[www.MetaWell.com](http://www.MetaWell.com)

## General Description

The PJ20301 is a 3 A low dropout linear regulator designed for low dropout and high current applications. This device works with dual supplies, a control input for the control circuitry and a power input as low as 1.0 V for providing current to output. It features 3 A output current and ultra-low-drop output voltage as well as full protection functions.  $V_{OUT}$  can be as low as 0.8V. The other features include soft start, under voltage protection, current limit protection, Power-On-Reset function, and over temperature protection. The PJ20301 is available in DFN3x3-10 and PSOP-8 packages.

## Simplified Schematic

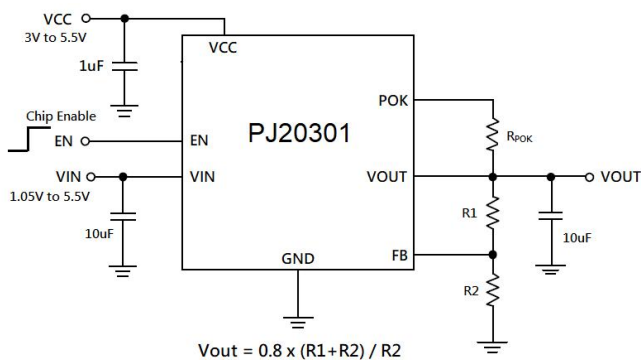

## Features

- ◆ Operating input voltage range : 1.0 V to 6.0 V
- ◆ Output voltage is Adjustable from 0.8 V (Min.)
- ◆ Maximum Output current : 3 A
- ◆ Dropout voltage : 250 mV at  $I_{OUT} = 3$  A (Typ.)
- ◆ Output voltage tolerance :  $\pm 1.5$  %
- ◆ Excellent Line Regulation (0.01 %/V typ.)
- ◆ Excellent Load Regulation (0.1 %/A typ.)
- ◆ Internal Thermal Overload Protection
- ◆ Internal Short-Circuit Current Limit
- ◆  $V_{OUT}$  Under Voltage Protection
- ◆ Ceramic Capacitor Stable
- ◆ Available in DFN3x3-10, PSOP-8 packages
- ◆ These devices are Pb-Free, halogen Free/BFR free, and are RoHS compliant

## Applications

- ◆ Notebook, Netbook, Graphic Cards
- ◆ Low Voltage Logic Supplies
- ◆ Chipset Supplies
- ◆ Server System
- ◆ SMPS Post Regulators

## Ordering Information

### Ordering Information

Order number	Marking ID	Package	Description
PJ20301QW	A1 YM DNN	DFN3x3-10	Halogen free RoHS compliant in T/R, 3,000 pcs/Reel
PJ20301PP	PJ20301 PPYMDNN	PSOP-8	Halogen free RoHS compliant in T/R, 4,000 pcs/Reel

Note:

(1) MetaWells can meet RoHS 2.0/REACH requirement. So most package types MetaWells offers only states halogen free, instead of lead free.

### Marking Information

Marking	Package	Definition
A1 YM DNN	DFN3x3-10	A1: Product code Y: Year code M: Month code D: Day code NN: Serial No.
PJ20301 PPYMDNN	PSOP-8	PJ20301: Product code PP: Package code Y: Year code M: Month code D: Day code NN: Serial No.

## Function Block Diagram

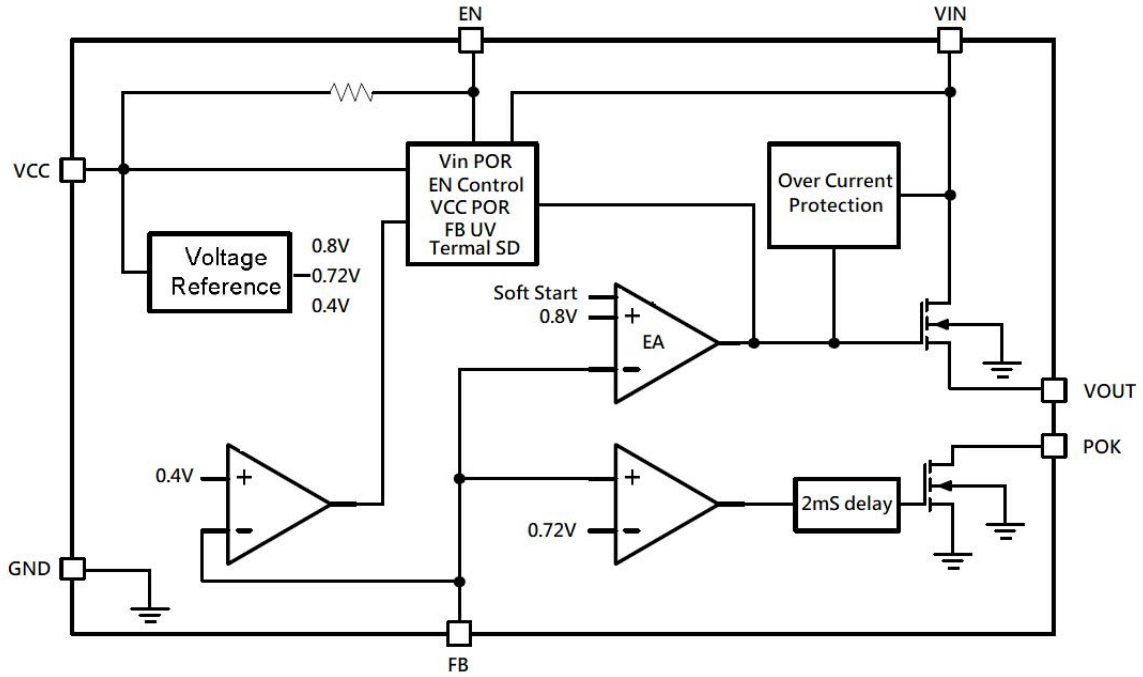

## Pin Configuration

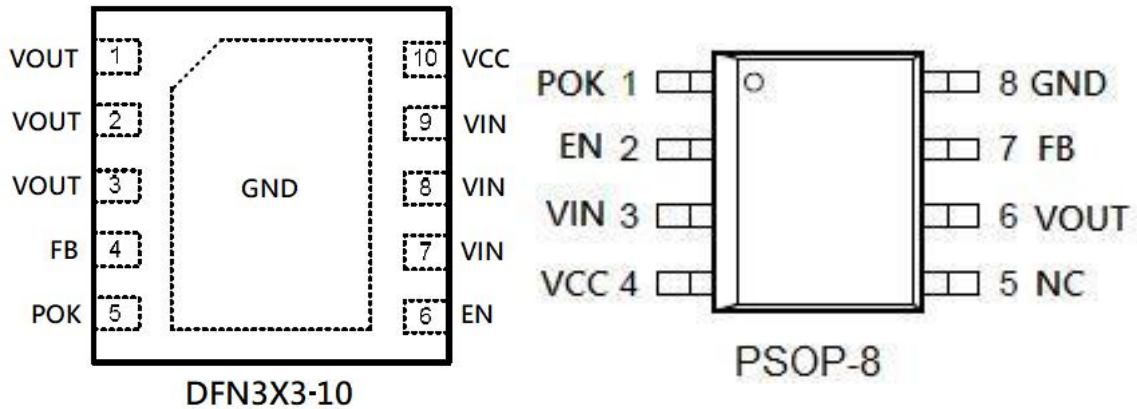

Pin Assignment (Top View)

## Pin Description

Name	Terminal		I/O <sup>(1)</sup>	Description
	PIN No. DFN3X3-10	PIN No. PSOP-8		
POK	5	1	O	Power OK indication, open drain output
FB	4	7	I	Feedback
VOUT	1, 2, 3	6	O	Output Voltage pin, the Source of power device
VIN	7, 8, 9	3	P	Input Voltage pin, the Drain of power device
EN	6	2	I	Enable pin. Internal pull high to VCC
VCC	10	4	I	Supply input of control circuit
GND	11 (Exposed PAD)	8 & (Exposed PAD)	G	Ground
NC	-	5	-	No Connect

(1) I – Input; O – Output; P – Power; G – Ground

## Absolute Maximum Ratings

Over operating free-air temperature range (unless otherwise noted) <sup>(1)</sup>

Parameter	Min	Max	Units
V <sub>IN</sub>	-0.3	6.5	V
V <sub>CC</sub>	-0.3	6.5	V
Other Pins	-0.3	V <sub>CC</sub> +0.3	V
Power Dissipation, PD@T <sub>A</sub> = 25°C, DFN3x3-10	1.53		W
Thermal Resistance, θ <sub>JA</sub> , DFN3X3-10	65		°C/W
Thermal Resistance, θ <sub>JC</sub> , DFN3X3-10	15		°C/W
Power Dissipation, PD@T <sub>A</sub> = 25°C, PSOP-8	1.81		W
Thermal Resistance, θ <sub>JA</sub> , PSOP-8	55		°C/W
Thermal Resistance, θ <sub>JC</sub> , PSOP-8	20		°C/W
Junction Temperature	125		°C
Lead Temperature(Soldering, 10 sec.)	300		°C
Storage temperature range	-65	150	°C

(1) Stresses beyond those listed under absolute maximum ratings may cause permanent damage to the device. These are stress ratings only, and functional operation of the device at these or any other conditions beyond those indicated under recommended operating conditions is not implied. Exposure to absolute-maximum-rated conditions for extended periods may affect device reliability.

## Handling Ratings

Parameter	Definition	Min	Max	Units
ESD <sup>(1)</sup>	Human Body Model (HBM) ESD stress voltage <sup>(2)</sup>	-2	2	kV
	Charged Device Model (CDM) ESD stress voltage <sup>(3)</sup> , all pins	-500	500	V

(1) Electrostatic discharge (ESD) to measure device sensitivity and immunity to damage caused by assembly line electrostatic discharges into the device.

(2) Level listed above is the passing level per ANSI, ESDA, and JEDEC JS-001. JEDEC document JEP155 states that 500-V HBM allows safe manufacturing with a standard ESD control process.

(3) Level listed above is the passing level per EIA-JEDEC JESD22-C101. JEDEC document JEP157 states that 250-V CDM allows safe manufacturing with a standard ESD control process.

## Recommended Operating Conditions

Symbol	Parameter	Min	Typ	Max	Units
V <sub>IN</sub>	Input voltage range	1.05	-	V <sub>CC</sub>	V
V <sub>CC</sub>	Control Voltage	3.0	-	5.5	V
T <sub>J</sub>	Operating junction temperature	-40	-	125	°C

## Electrical Characteristics

$V_{CC} = 5\text{ V}$ ,  $C_{IN} = C_{OUT} = 10\ \mu\text{F}$ ,  $C_{VCC} = 1\ \mu\text{F}$ . Typical value is tested at  $T_A = +25^\circ\text{C}$ , unless otherwise noted.

Symbol	Parameter	Condition	Min	Typ	Max	Unit
$V_{CC}$	Control input voltage	$V_{OUT} = V_{REF}$	3.0		6.0	V
$V_{CC\_POR}$	POR threshold voltage		2.2		2.9	V
$V_{CC\_POR\_HY}$	POR hysteresis voltage			0.4		V
$V_{IN}$	Input voltage	$V_{OUT} = V_{REF}$	1.05		$V_{CC}$	V
$V_{IN\_POR}$	POR threshold voltage		0.8		1.0	V
$V_{IN\_POR\_HY}$	POR hysteresis voltage			0.35		V
$T_{DEG}$	POR deglitch time			100		$\mu\text{s}$
$I_{VCCSD}$	Control input current in shutdown	$V_{IN} = V_{CC} = 5\text{ V}$ , $V_{EN} = 0\text{ V}$		10	30	$\mu\text{A}$
$I_Q$	Quiescent current	$V_{IN} = V_{CC} = V_{EN} = 5\text{ V}$ , $I_{OUT} = 0\text{ A}$		0.9	1.5	mA
$V_{REF}$	Reference voltage	$V_{IN} = V_{CC} = V_{EN} = 5\text{ V}$ , $I_{OUT} = 0\text{ A}$ , $V_{OUT} = V_{REF}$	0.785	0.8	0.815	V
$V_{REFLINE}$	Line regulation	$1.05\text{ V} < V_{IN} < 5\text{ V}$ , $V_{CC} = V_{EN} = 5\text{ V}$		0.01	0.1	%/V
$V_{REFLOAD}$	Load regulation	$0\text{ A} < I_{OUT} < 3\text{ A}$ , $V_{CC} = V_{EN} = 5\text{ V}$		0.1	0.5	%/A
$V_{DROP}$	Dropout voltage	$I_{OUT} = 3\text{ A}$ , $V_{CC} = 5\text{ V}$ , $V_{OUT} = 1.2\text{ V}$		250	360	mV
$R_{PULL}$	$V_{OUT}$ pull low resistance	$V_{CC} = 5\text{ V}$ , $V_{EN} = 0\text{ V}$ , Sink = 5 mA			150	Ohm
$V_{IH}$	EN pin threshold voltage	EN logic high voltage	1.1			V
$V_{IL}$		EN logic low voltage			0.3	V
$I_{EN}$	Enable source current	$V_{CC} = 5\text{ V}$ , $V_{EN} = 0\text{ V}$		5	10	$\mu\text{A}$
$R_{EN}$	EN pull-high resistor		500			k $\Omega$
$T_{SS}$	Output voltage ramp-up time		0.6	1	2	mS
$V_{POK\_H}$	POK Threshold	$V_{FB}$ rising		92		%
$V_{POK\_L}$	POK Threshold	$V_{FB}$ falling		82		%
$V_{POK\_SINK}$	POK sink voltage	Sinking current = 5 mA			0.4	V
$t_{POK\_DELAY}$	POL delay time	From $V_{OUT} > 92\%$ to POK rising	1	2	4	mS
$I_{OCP}$	OCP threshold level		3.2	4.5		A
$V_{UVP}$	Under voltage threshold	$V_{FB}$ Falling		0.15		V
$T_{SD}$	Thermal shutdown threshold			165		$^\circ\text{C}$
$T_{SD\_HYS}$	Thermal shutdown hysteresis			30		$^\circ\text{C}$

**Note:**

(1) It is not recommended to use at  $125^\circ\text{C}$  without load.

## Typical Performance Characteristic

$V_{IN} = 5\text{ V}$ ,  $V_{CC} = 5\text{ V}$ ,  $V_{OUT} = 0.8\text{ V}$ ,  $C_{IN} = 10\text{ }\mu\text{F}$ ,  $C_{OUT} = 10\text{ }\mu\text{F}$ ,  $T_A = 25^\circ\text{C}$ , unless otherwise specified.

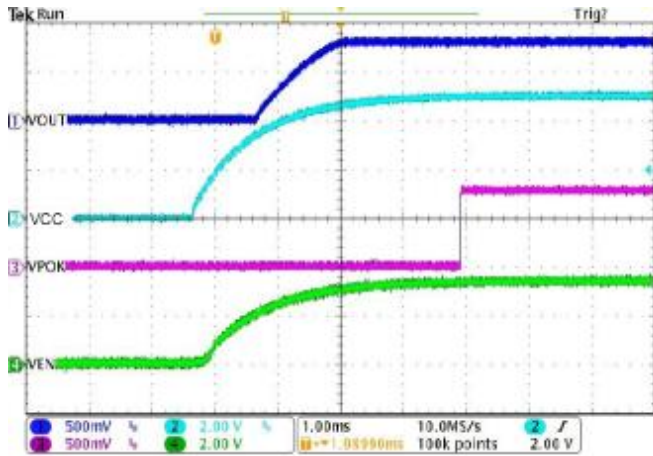

Figure-1.  $V_{CC}$  Power ON,  $I_{OUT} = 200\text{ mA}$

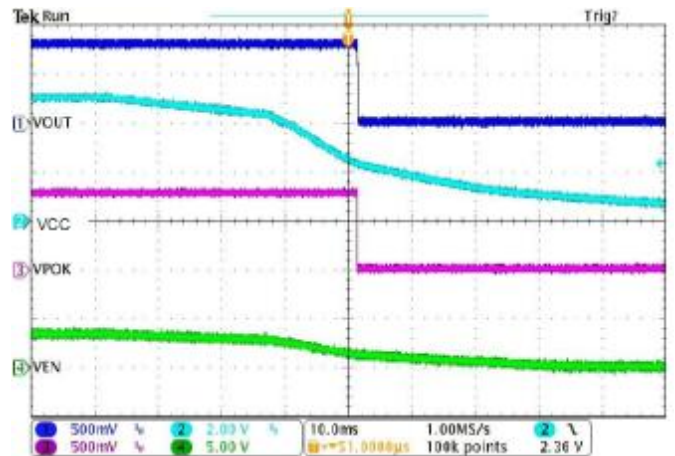

Figure-2.  $V_{CC}$  Power OFF,  $I_{OUT} = 200\text{ mA}$

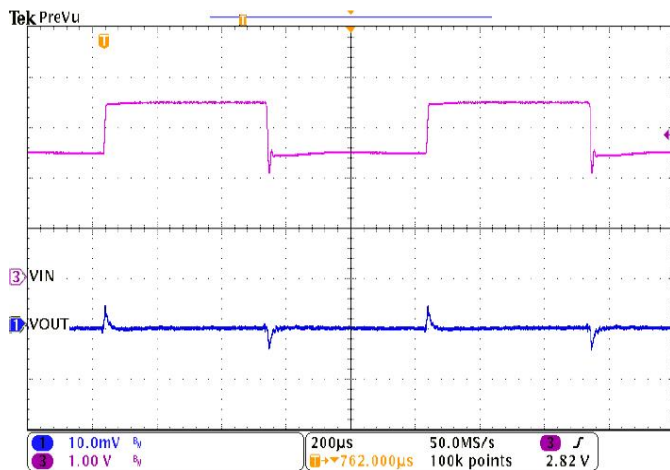

Figure-3. Line Transient,  $V_{IN} = 2.5\text{ V to } 3.5\text{ V}$

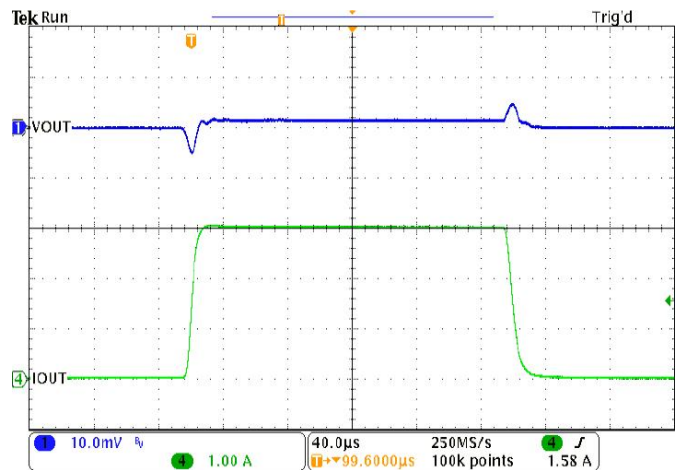

Figure-4. Load Transient,  $I_{OUT} = 0\text{ A to } 3\text{ A}$

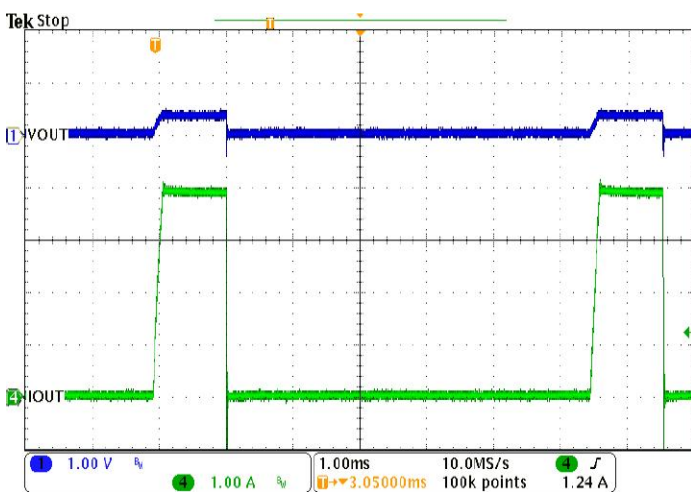

Figure-5.  $V_{OUT}$  Short circuit

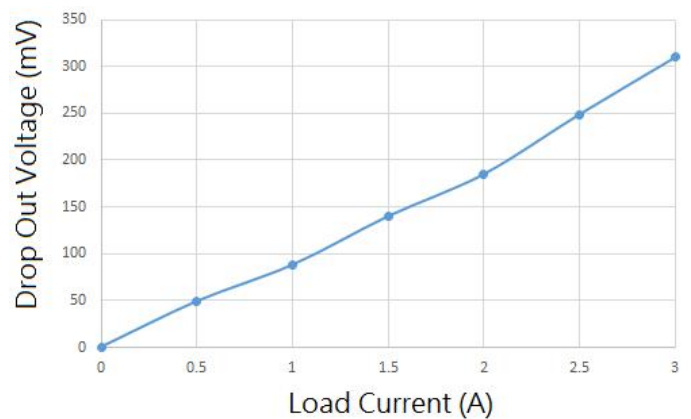

Figure-6.  $V_{DROP}$  vs Output Current

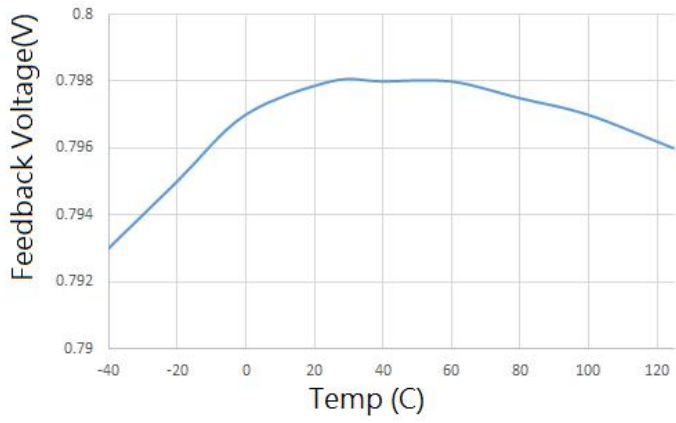

Figure-7.  $V_{FB}$  Voltage vs Temperature

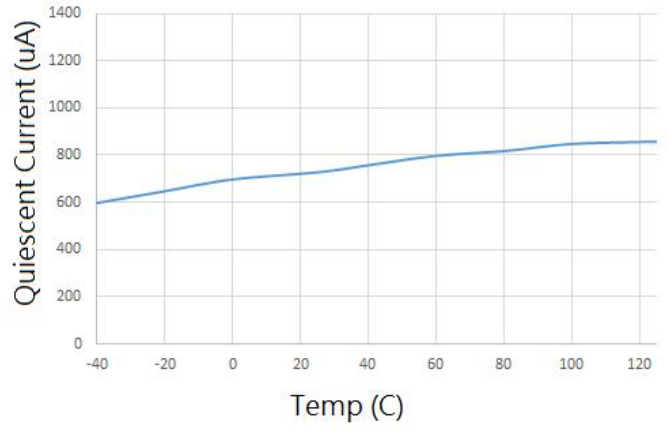
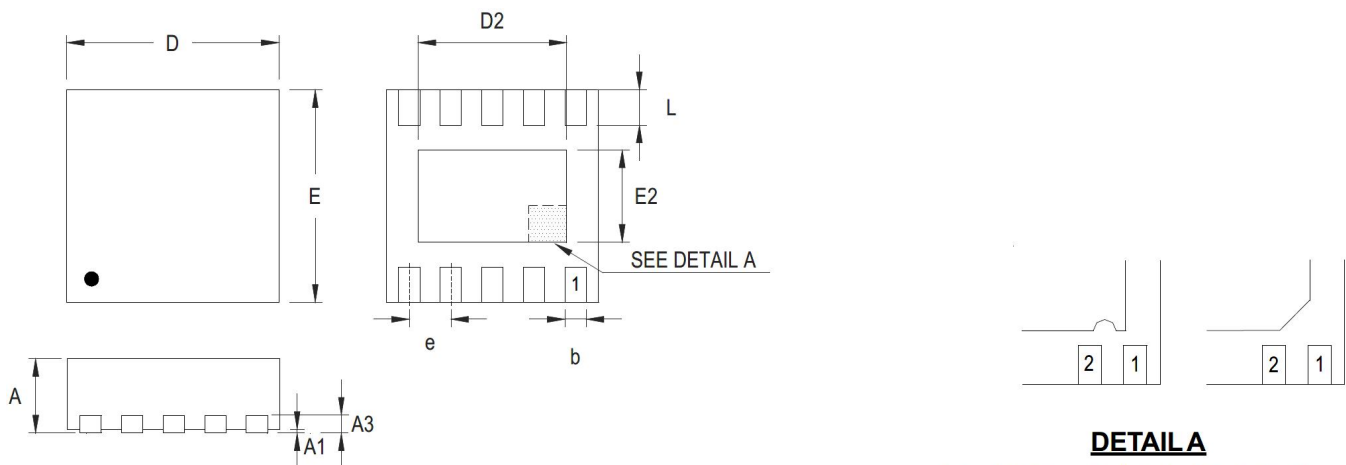

Figure-8. Quiescent Current vs Temperature

## Package Dimension - DFN3X3-10



### DETAIL A

Pin #1 ID and Tie Bar Mark Options

Note : The configuration of the Pin #1 identifier is optional, but must be located within the zone indicated.

Symbol	Dimensions In Millimeters		Dimensions In Inches	
	Min	Max	Min	Max
A	0.700	0.800	0.028	0.031
A1	0.000	0.050	0.000	0.002
A3	0.175	0.250	0.007	0.010
b	0.180	0.300	0.007	0.012
D	2.950	3.050	0.116	0.120
D2	2.300	2.650	0.091	0.104
E	2.950	3.050	0.116	0.120
E2	1.500	1.750	0.059	0.069
e	0.500		0.020	
L	0.350	0.450	0.014	0.018

## Package Dimension - PSOP-8

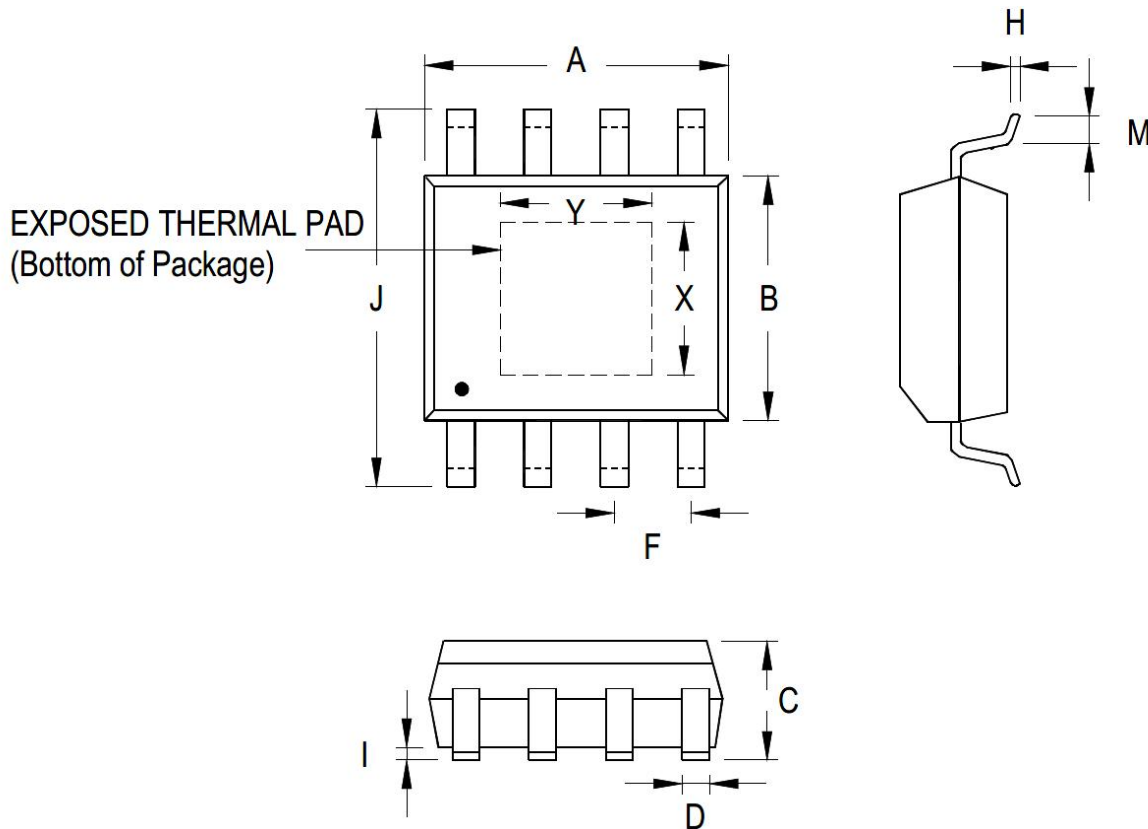

Symbol	Dimensions In Millimeters		Dimensions In Inches		
	Min	Max	Min	Max	
A	4.801	5.004	0.189	0.197	
B	3.810	4.000	0.150	0.157	
C	1.346	1.753	0.053	0.069	
D	0.330	0.510	0.013	0.020	
F	1.194	1.346	0.047	0.053	
H	0.170	0.254	0.007	0.010	
1	0.000	0.152	0.000	0.006	
J	5.791	6.200	0.228	0.244	
M	0.406	1.270	0.016	0.050	
Option 1	X	2.000	2.300	0.079	0.091
	Y	2.000	2.300	0.079	0.091
Option 2	X	2.100	2.500	0.083	0.098
	Y	3.000	3.500	0.118	0.138

## Version History

Version	Date	Changes
Rev.1.0	2025-10-23	Initial release.
Rev.1.1	2026-02-06	Updated Absolute Maximum Ratings table.

## Disclaimer

MetaWells Co., Ltd. and all other MetaWells Co., Ltd. trademarks are the exclusive property of MetaWells Co., Ltd.. Any mention of additional trademarks or registered trademarks in this document is made in acknowledgment of their respective owners.

Without the consent of MetaWells Co., Ltd. , any modification to any part or subsection of the company's product specifications and datasheets is strictly prohibited in any form or manner. MetaWells Co., Ltd. reserves the rights to make changes of the content herein the document follow PCN procedure. Please refer to our website for latest document. It is recommended that customers obtain the latest version of relevant information and verify its timeliness and completeness before placing an order. All products are sold in accordance with the terms and conditions provided in the sales contract at the time of order confirmation, which includes warranty scope, intellectual property rights, and liability limitations.

During the sales period, MetaWells Co., Ltd. guarantees that the performance of the products will be in accordance with the company's standard warranty. The company utilizes testing and other quality control techniques to ensure the necessity to maintain this warranty. Except for government-mandated requirements, there is no need for special testing of measurement tables or other instruments.

Customers must acknowledge that our products are not intended or manufactured for use in life support systems or other high-risk activities or environments. The utilization of our products in such applications may lead to severe consequences, including personal injury, loss of life, property damage, or environmental harm. Our products are explicitly not warranted for deployment in high-risk activities, and we shall bear no responsibility towards customers or third parties for such usage.

MetaWells Co., Ltd. commits to providing technical support, assistance, advice, and information, in line with our current capabilities, including guidance related to the design, development, or debugging of purchased boards or other applications. However, we hereby disclaim all warranties concerning technical support, merchantability, or fitness for a particular purpose. We do not guarantee the error-free operation of boards or applications in conjunction with our support services, and we shall not be held liable for any consequences arising from the utilization of our support services.

**Copyright© MetaWells Co., Ltd.**

**Website : [www.MetaWells.com](http://www.MetaWells.com)**