

PJ30099 Datasheet

Low Quiescent Current Boost Converter

Version: Rev.1.1

Release Date: 2025-11-24

MetaWells Co., Ltd.

www.MetaWells.com

General Description

The PJ30099 is a synchronous step-up DC-DC converter, which integrated 280mΩ N-channel MOSFET switch and 360mΩ synchronous rectifier P-Channel MOSFET to provide a high efficiency solution at nearly 95%.

The PJ30099 is based on a peak-current control which provides a power-supply solution for products powered by either a single-cell, two-cell, or three-cell alkaline, NiCd or NiMH, or one-cell Li-Ion or Li-polymer battery such as input voltage at 0.75V.

The output voltage of the converter can be adjusted by an external resistor divider from 1.8V to 5V.

The PJ30099 is available in a space-saving SOT23-6 package.

Features

- ◆ Low I_Q , 5.5μA Operating Quiescent Current
- ◆ Up to 95% Efficiency at Typical Operating Conditions
- ◆ Operating Input Voltage from 0.75V to 5V
- ◆ Feedback Voltage 500mV
- ◆ 550mA Switching Current Limit
- ◆ Adjustable Output Voltage from 1.8V to 5V
- ◆ Very Low 0.2μA Shutdown Current
- ◆ Minimum Switching Current 200mA
- ◆ Input Under Voltage Lockout
- ◆ Output Overvoltage Protection
- ◆ Over-Temperature Protection
- ◆ SOT23-6 Package

Applications

- ◆ Battery Powered Applications
 - 1 to 3 Cell Alkaline, NiCd or NiMH
 - 1 Cell Li-Ion or Li-Primary
- ◆ Handheld Instrument
- ◆ GPS Receiver
- ◆ Solar or Fuel Cell Powered Applications
- ◆ Consumer and Portable Medical Products
- ◆ White or Status LEDs

Ordering Information

Ordering Information

Order number	Marking ID	Package	Description
PJ30099S6	AD DNN	SOT23-6	Halogen free RoHS compliant in T/R,3,000pcs/Reel

Marking Information

Marking	Package	Definition
AD DNN	SOT23-6	AD: Product code D: Date code NN: Serial number

Typical Application

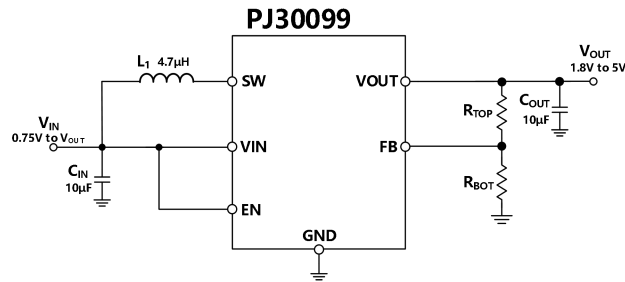

Figure 1. Typical Application of PJ30099

Pin Configuration

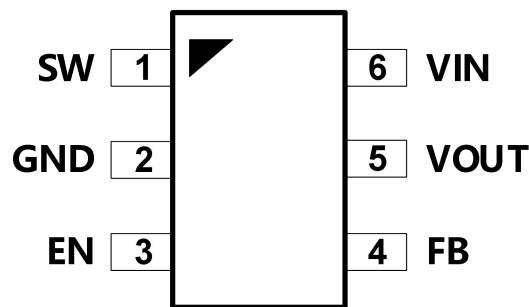

Figure 2. SOT23- 6 Pin configuration (Top View)

Functional Pin Description

Pin No	Pin Name	Type ⁽¹⁾	Description
1	SW	I	Rectifying switch input which is connected to inductor.
2	GND	G	Ground pin.
3	EN	A, I	Enable input. Drive EN logic high to turn on the converter; drive EN logic low to turn off the converter.
4	FB	A, I	Feedback node. Connect this pin to the middle point of an external resistor divider from VOUT to GND to set the output voltage.
5	VOUT	P, O	Output voltage pin.
6	VIN	I	Input power supply pin.

(1). A = Analog Pin ; P = Power Pin ; D = Digital Pin ; I = Input Pin ; O = Output Pin ; G=Ground.

Specifications

Absolute Maximum Ratings

Parameter	Min	Max	Unit
VIN, VOUT, EN, FB	-0.3	6	V
SW Voltage	-0.3	6	V
SW Voltage <10ns Transient	-1	7.5	V
Continuous Power Dissipation	0.5		W
Junction temperature	-40	150	°C
Storage temperature	-65	150	°C
Lead temperature (soldering, 10sec.)		260	°C

- (1). Stresses at or above those listed under Absolute Maximum Ratings may cause permanent damage to the product. This is a stress rating only; functional operation of the product at these or any other conditions above those indicated in the operational section of this specification is not implied. Operation beyond the maximum operating conditions for extended periods may affect product reliability.

Handling Ratings

Parameter	Description	Rating	Unit
HBM	Human Body Model ANSI/ESDA/JEDEC JS-001-2014 Classification, Class: 2	±2000	V
CDM	Charged Device Model ANSI/ESDA/JEDEC JS-002-2014 Classification, Class: C0b	±750	V
Latch-Up	JEDEC STANDARD NO.78E APRIL 2016 Temperature Classification, Class: I	±100	mA

Recommended Operating Conditions

Parameter	Min	Typ	Max	Unit
Operating Temperature	-40		85	°C
Continuous Supply Voltage (VIN)	0.75		5	V
Output Voltage (VOUT)	1.8		5	V
Junction Temperature (TJ)	-40		125	°C

Thermal Resistance

Thermal performance is directly linked to printed circuit board (PCB) design and operating environment. Close attention to PCB thermal design is required.

Item ⁽¹⁾⁽²⁾	Description	Value	Unit
θ_{JA}	Junction-to-ambient thermal resistance	195	°C/W
θ_{JC_Top}	Junction-to-case (top) thermal resistance	135	°C/W

- (1). The package thermal impedance is calculated in accordance to JESD 51-7.
 (2). Thermal Resistances were simulated on a 4-layer, JEDEC board.

Electrical Specifications

Typical values represent the most likely parametric norm at $T_A = 25^\circ\text{C}$, and are provided for reference purposes only. Unless otherwise stated the following conditions apply: $V_{IN} = 1.2\text{V}$. V_{OUT} is converter output voltage.

Parameter	Symbol	Test Conditions	Min	Typ	Max	Unit
DC-DC stage						
Minimum Start-up Voltage	V_{ST}	$R_{load} \geq 150\Omega$			0.75	V
Input Power Range	V_{IN}		0.75		5	V
Output Voltage Range	V_{OUT}	$V_{IN} \leq V_{OUT}$	1.8		5	V
Undervoltage Lockout(UVLO) Falling threshold	V_{UVLO}	V_{IN} decreasing	0.5	0.55	0.65	V
Shutdown Current from Power Source	I_{SD}	$EN=0V$		0.1	0.5	μA
Quiescent Current (V_{IN})	I_Q	$V_{EN}=V_{IN}=1.2V, V_{OUT} = 3.3V,$ Non-switching		2.95	5	μA
Quiescent Current (V_{OUT})				0.2	1.5	μA
Switch Current limit	I_{LIM}	$V_{OUT}=3.3V, V_{IN}=1.2V$		0.55		A
Feedback Voltage	V_{FB}		492	500	508	mV
FB Input Bias Current	I_{FB}	$V_{FB}=0.5V$		0.01	100	nA
NMOS Switch ON Resistance	$R_{DS(ON)}$	$V_{OUT}=3.3V$		0.28	0.45	Ω
PMOS Switch ON Resistance	$R_{DS(ON)}$	$V_{OUT}=3.3V$		0.36	0.52	Ω
Operating Frequency	f_{SW}	$V_{IN}=1.2V, V_{OUT}=2.2V,$ $I_{OUT}=120\text{mA}$		500		kHz
ENABLE (EN)						
EN Input Low Voltage	V_{IL}	$V_{IN} < 1.5V$	$0.2 \times V_{IN}$			V
EN Input High Voltage	V_{IH}	$V_{IN} < 1.5V$			$0.8 \times V_{IN}$	V
EN Input Low Voltage	V_{IL}	$1.5V < V_{IN} < 5V$	0.4			V
EN Input High Voltage	V_{IH}	$1.5V < V_{IN} < 5V$			1.2	V
EN Input Current		$EN=GND$ or V_{IN}		0.01	100	nA
Protections						
Over-Voltage Protection	V_{OVP}		5.5			V
Over-Temperature Protection	T_{SD}			150		$^\circ\text{C}$
Over-Temperature Hysteresis	T_{SD_HYS}			20		$^\circ\text{C}$

Typical Performance Characteristic

$V_{IN}=1.2V$, $V_{OUT}=3.3V$, $L=2.2\mu H^{(1)}$, $C_{OUT}=20\mu F$, $T_A=25^\circ C$, unless otherwise noted.

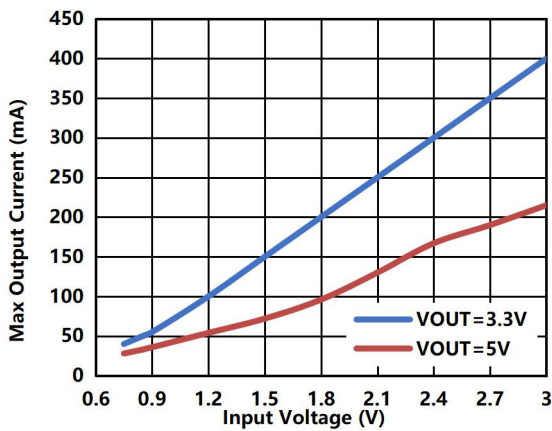

Figure 3. Maximum Output Current vs. Input Voltage

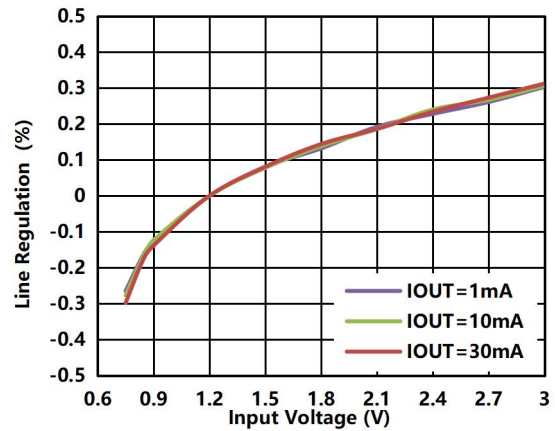

Figure 4. Line Regulation ($V_{OUT}=3.3V$)

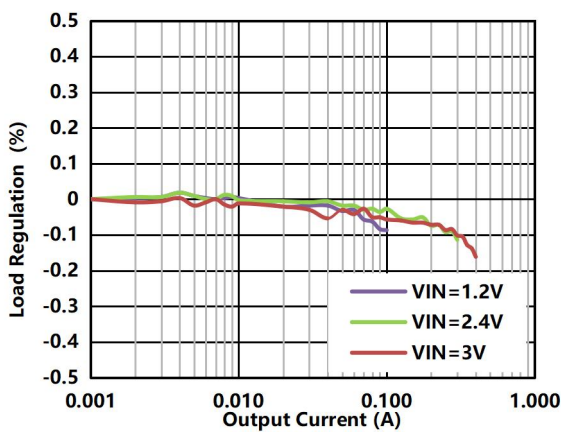

Figure 5. Load Regulation ($V_{OUT}=3.3V$)

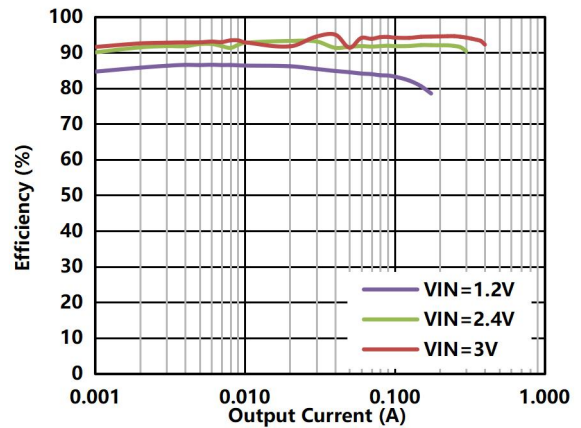

Figure 6. Efficiency vs. Output Current ($V_{OUT}=3.3V$)

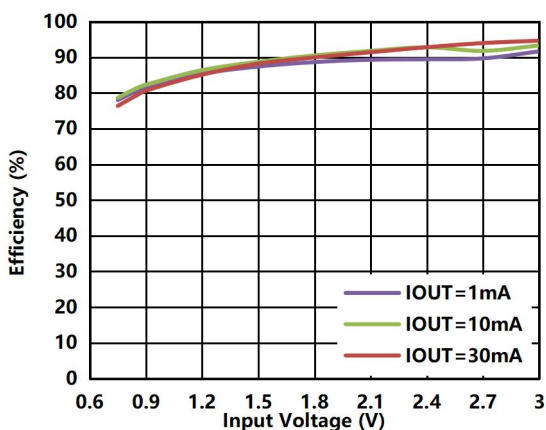

Figure 7. Efficiency vs. Input Voltage ($V_{OUT}=3.3V$)

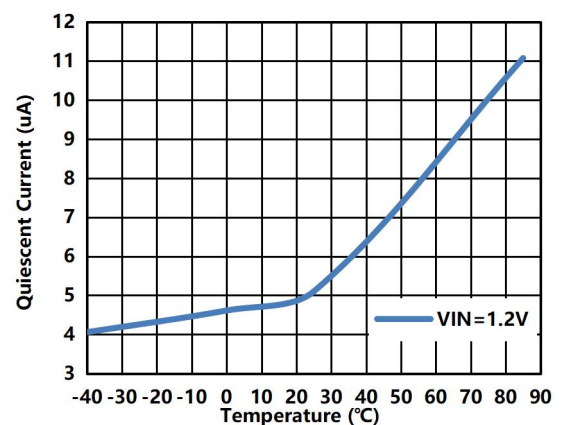

Figure 8. Quiescent current vs. Temperature ($V_{OUT}=3.3V$)

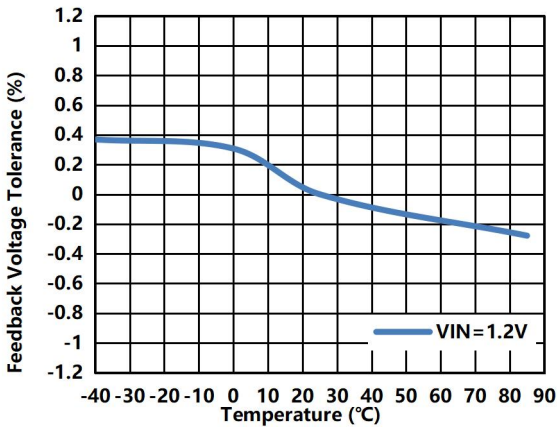

Figure 9. Feedback Voltage tolerance vs. Temperature ($V_{OUT}=3.3V$)

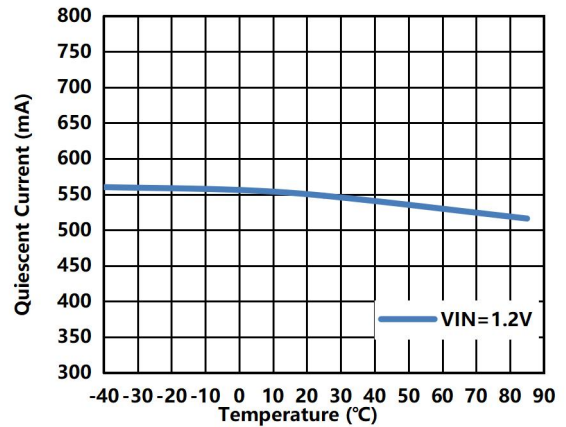

Figure 10. Top Current Limit vs. Temperature ($V_{OUT}=3.3V$)

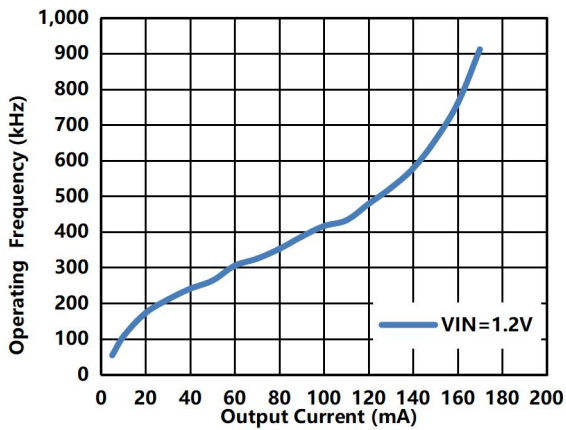

Figure 11. Operating Frequency vs. Output Current ($V_{OUT}=2.2V$)

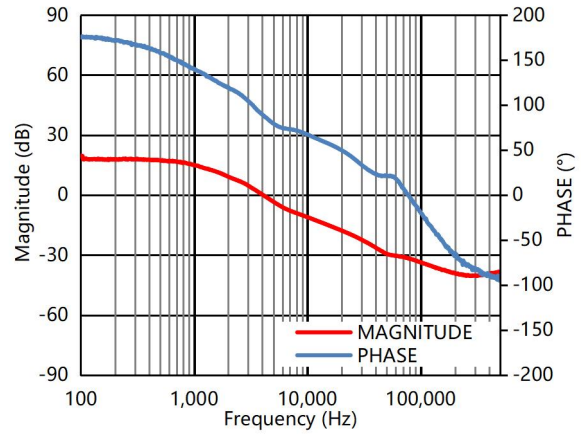

Figure 12. Loop Gain, $V_{IN}=1.2V$, $V_{OUT}=3.3V$, $I_{OUT}=100mA$

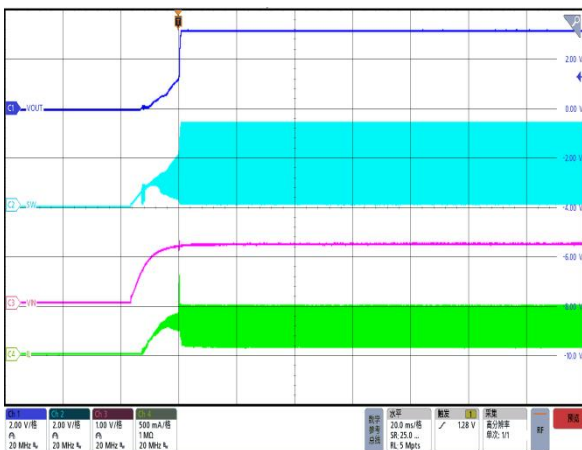

Figure 13. Power On by V_{IN} , $V_{IN}=1.2V$, $V_{OUT}=3.3V$, $I_{OUT}=90mA$

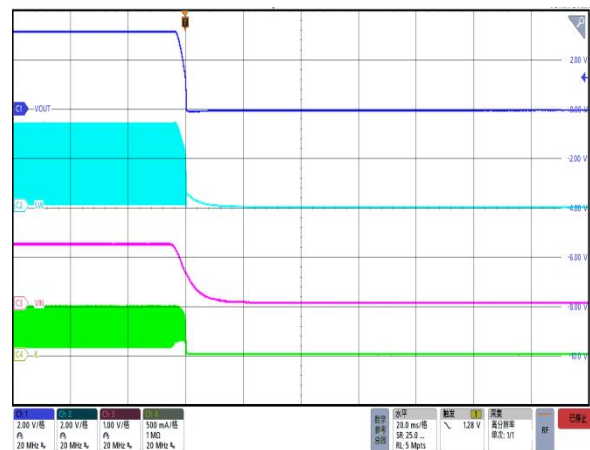

Figure 14. Power Off by V_{IN} , $V_{IN}=1.2V$, $V_{OUT}=3.3V$, $I_{OUT}=90mA$

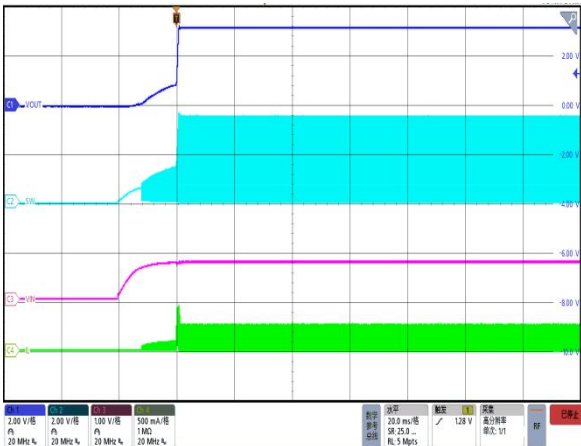

Figure 15. Power On by V_{IN} , $V_{IN}=0.75V$, $V_{OUT}=3.3V$, $I_{OUT}=5mA$

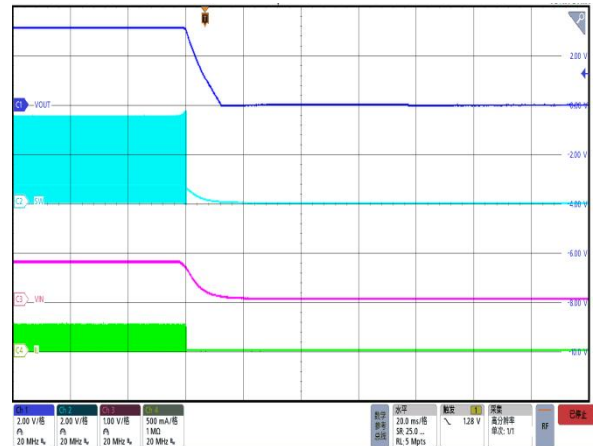

Figure 16. Power Off by V_{IN} , $V_{IN}=0.75V$, $V_{OUT}=3.3V$, $I_{OUT}=5mA$

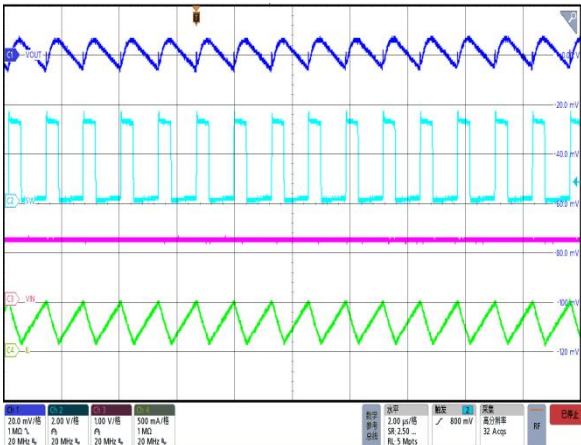

Figure 17. Switching Waveform, $V_{IN}=1.2V$, $V_{OUT}=3.3V$, $I_{OUT}=90mA$

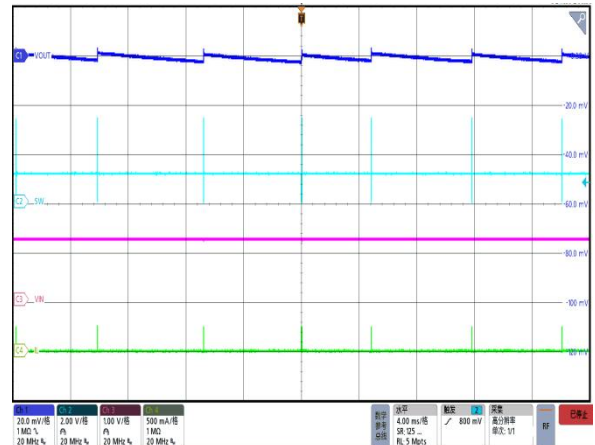

Figure 18. Switching Waveform, $V_{IN}=1.2V$, $V_{OUT}=3.3V$, $I_{OUT}=0mA$

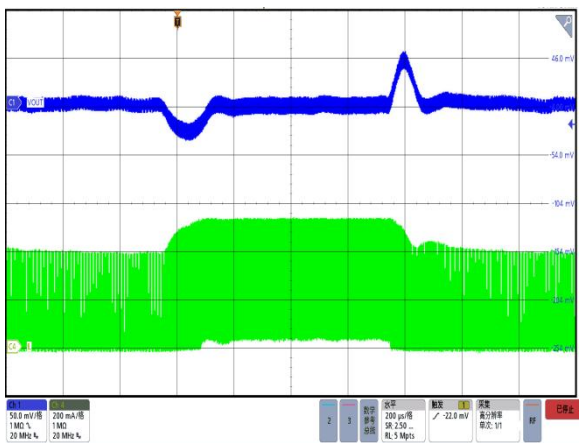

Figure 19. Load Transient, $V_{IN}=1.2V$, $V_{OUT}=3.3V$, 20mA to 90mA

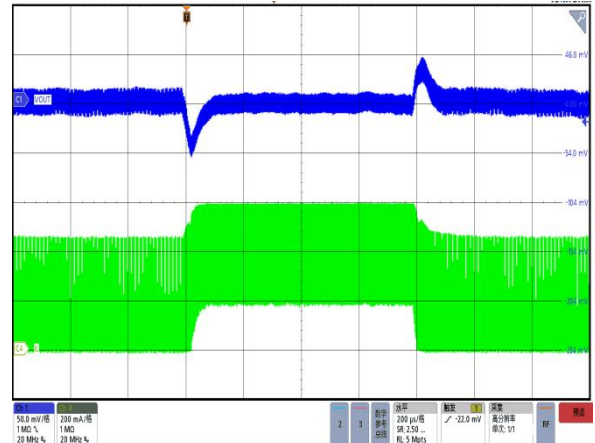

Figure 20. Load Transient, $V_{IN}=2.4V$, $V_{OUT}=3.3V$, 60mA to 250mA

Note:

(1). Inductor PN: XAL5030-222MEC; DCR=13.20mΩ.

Functional Block Diagram

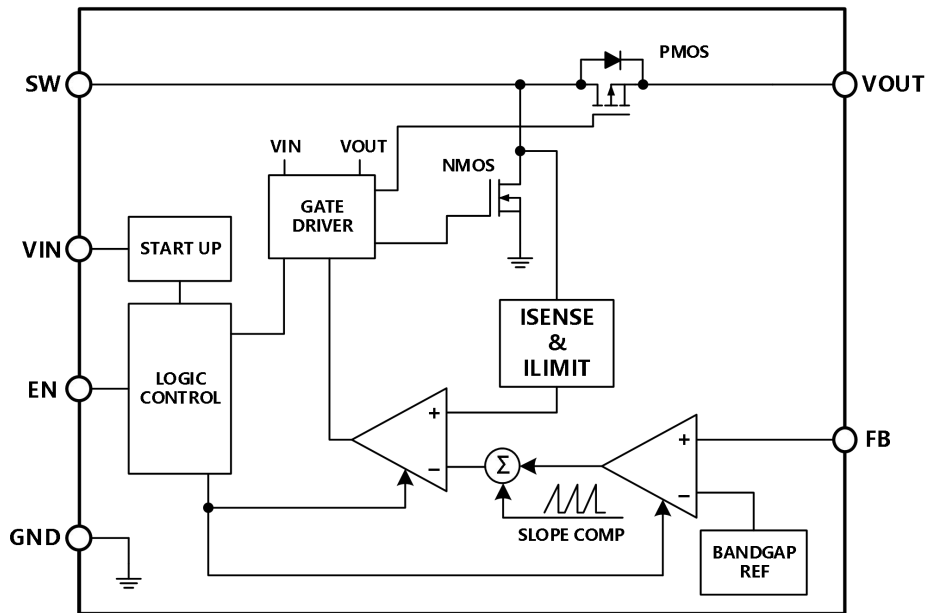

Figure 21. Functional Block Diagram

Product Overview

The PJ30099 is a high performance, highly efficient synchronous boost converter. The device operates with an input voltage from 0.75V to 5V and provides an adjustable output voltage from 1.8V to 5V. With the low quiescent current down to 5.5 μ A, it is highly adaptable to the products powered by either a single-cell, two-cell, or three-cell alkaline, NiCd or NiMH, or one-cell Li-Ion or Li-polymer battery.

The PJ30099's protection features include undervoltage lockout, output overvoltage protection, over temperature protection.

Controller Circuit

It employs peak-current-mode control to regulate the output voltage. The PJ30099 is a peak current mode controller boost converter. Its typical maximum peak switch current is 550mA, and the minimum switch current is 200mA when the output voltage exceeds 1.8V. This controller regulates the output voltage by adjusting the peak inductor current based on the load current, thereby achieving precise output voltage regulation. The PJ30099 employs three load-dependent control modes. When the required average input current falls below the average inductor current determined by the minimum switch current (200mA), the converter enters Discontinuous Conduction Mode (DCM), maintaining high efficiency under light loads. If the load current decreases further, it transitions into Burst Mode. In this mode, the boost converter ramps up the output voltage with a switching cycle. Once the output voltage exceeds the set threshold, the controller stops switching and enters a sleep state with quiescent current as low as microamps (μ A). The converter resumes the third operating mode (Continuous Conduction Mode, CCM) when the load increases or output voltage drops below the threshold. In CCM, no fixed switching frequency is set. As the load increases, the boost converter actively modulates the output voltage by simultaneously enhancing the peak inductor current and reducing the switching period. The device achieves maximum load capability once the switching frequency reaches the fundamental limit defined by the high-side MOSFET's minimum on-time (t_{onmin}). The regulator is internally compensated and it integrated a slope compensation circuitry to avoid the subharmonic oscillation phenomenon when the duty cycle is above 50%.

Synchronous Rectifier

The device integrates an N-channel and a P-channel MOSFET transistor to realize a synchronous rectifier. There is no additional Schottky diode required. Because the device uses an integrated low $R_{DS(ON)}$ PMOS switch for rectification, the power conversion efficiency reaches 95%.

Enable and Shutdown

The PJ30099 uses the EN pin to enable and disable the device under normal operating condition. Pull this pin high to enable the device; pull this pin low to shut down the device. In shutdown mode, the regulator stops switching and all internal control circuitry is turned off. In this case the input voltage is connected to the output through the back-gate diode of the rectifying P-Channel MOSFET so that the output voltage is always lower than input voltage. If this feature is not needed, connect this pin directly to V_{IN} to start up the device with V_{IN} rising to its internal UVLO threshold.

Start Up

When EN is pulled high, the device starts to operate. When V_{OUT} is below 1.7V, the duty cycle is limited in order to avoid high peak currents drawn from the battery. The limit is set internally by the current limit circuit. As soon as the device has built up the output voltage to about 1.7 V, high enough for supplying the control circuit, the device switches to its normal peak current mode operation. The startup time depends on input voltage and load current.

Operation at Inductor Current Limit

If in normal boost operation the inductor current reaches the internal switch current limit threshold the main switch is turned off to stop further increase of the input current. In this case the output voltage will decrease since the device can not provide sufficient power to maintain the set output voltage. If the output voltage drops below the

input voltage the backgate diode of the rectifying switch gets forward biased and current starts flow through it. This diode cannot be turned off, so the current finally is only limited by the remaining DC resistances. As soon as the overload condition is removed, the converter resumes providing the set output voltage.

Undervoltage Lockout (UVLO)

The PJ30099 features the undervoltage lockout protection for the occurrence of power-on glitch or malfunctioning of the converter. If the V_{IN} drops below the falling threshold, the device shuts down. V_{IN} UVLO is a non-latch protection.

Overvoltage Protection (OVP)

The PJ30099 features the over-voltage protection for the output voltage against an output short to an higher voltage supply to avoid the output voltage exceeding critical values for the device and possibly for the system it is supplying. For this protection the PJ30099 output voltage is also monitored internally. When the output voltage of the PJ30099 exceeds the over-voltage protection threshold, the converter stops switching.

Overtemperature Protection (OTP)

The PJ30099 monitors the die temperature. If the junction temperature exceeds 150°C , the internal thermal shutdown circuitry turns off the regulator, stops the MOSFET switching. Overtemperature Protection is a non-latch protection, when the junction temperature falls below to 130°C , the parts resumes normal operation automatically.

Typical Application Circuit

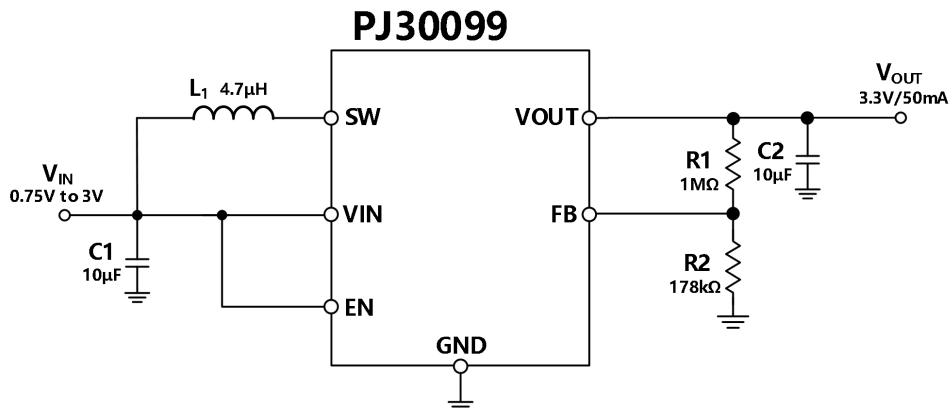

Figure 22. Typical Application Circuit

Application Information

Component selection steps are described in this section based on the example specifications listed in *Parameter of Design Example Table*. The schematic of this design example is showed in Figure 22. Typical Application Circuit

Parameter of Design Example

Parameter	Description
Input Voltage	$V_{IN}=0.75V$ to $3V$
Output Voltage	$V_{OUT}=3.3V$
Output Current	$I_{OUT}=50mA$

Output Voltage Setting

The output voltage of the PJ30099 is set by the external resistor divider showed in Figure 22. Typical Application Circuit. When the output voltage is regulated properly, the typical voltage value at the FB pin is 500 mV. The maximum recommended value for the output voltage is 5 V. The current through the resistive divider should be about 100 times greater than the current into the FB pin. The typical current into the FB pin is $0.01\mu A$, and the voltage across the resistor between FB and GND is typically 500 mV. Based on those two values, the recommended value for R1 is in the range of $1M\Omega$. Use the following equation to calculate resistor value of resistor R2,

$$R2 = \frac{V_{FB} \times R1}{V_{OUT} - V_{FB}}$$

where:

$V_{FB}=500mV$, $V_{OUT}=3.3V$, $R1=1M\Omega$.

Inductor Selection

The inductor value is determined by the switching frequency, input voltage, output voltage, and inductor ripple current. The performance of the inductor affects the transient behavior, efficiency, loop stability. For PJ30099, the Inductor values of $4.7\mu H$ show good performance over the whole input and output voltage range.

Use the following equation to choose other inductance values:

$$L = \frac{V_{IN}}{\Delta I_L \times f_{SW}} \times \left(1 - \frac{V_{IN}}{V_{OUT}}\right)$$

Using a larger inductor value than 4.7μH reduces the output ripple current and then reduces the output voltage ripple, and also leads to better efficiency, but it leads to slower transient behavior. A smaller inductor value offers a fast transient behavior, but it leads to larger inductor ripple current and then decreases efficiency. Using inductor values below 2.2 μH is not recommended.

Input Capacitor Selection

At least a 10-μF input capacitor is recommended to improve transient behavior of the regulator and EMI behavior of the total power supply circuit. To filter the high frequency switching noise, it is recommended that use a lower value capacitor(0.1uF) with 0603 package size. Place the input capacitor as close as possible to the V_{IN} pin.

Output Capacitor Selection

The major parameter necessary to define the output capacitor is the maximum allowed output voltage ripple of the converter. The selection of the output capacitor is based on two parts. One is determined by the inductor ripple current going through the ESR of the output capacitors, and the other is determined by the inductor current ripple charging and discharging the output capacitor. Using the following equation to calculate the minimum capacitance needed for the defined ripple, supporting that the ESR is zero:

$$C_{OUT} = \frac{I_{OUT}(V_{OUT} - V_{IN})}{f \times \Delta V_{OUT_RIPPLE} \times V_{OUT}}$$

The total ripple is larger due to the ESR of the output capacitor. Using the following equation to calculate the output capacitor ripple:

$$\Delta V_{OUT_ESR} = \Delta I_L \times R_{ESR}$$

So ceramic capacitors with low ESR are strongly recommended for their small size and low output voltage ripple, which is recommended to place as close as possible to the V_{OUT} and GND pins of the IC.

A minimum capacitance value of 4.7 μF should be used, 10 μF are recommended.

Thermal Information

The maximum junction temperature (T_J) of the PJ30099 devices is recommended to 150°C. The thermal resistance of the SOT-23-6 package is θ_{JA}=195°C/W. Specified regulator operations are assured to ambient temperature (T_A) of 25°C. Therefore, the maximum power dissipation is about 500mW. More power can be dissipated if the maximum ambient temperature of the application is lower.

$$P_{D_MAX} = \frac{T_{J_MAX} - T_A}{\theta_{JA}} = 500mW$$

Package Outline Dimensions

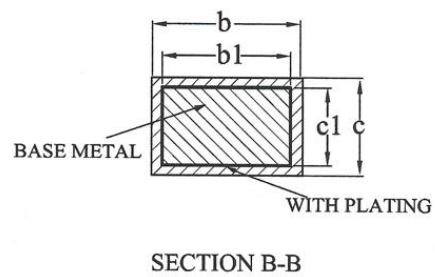
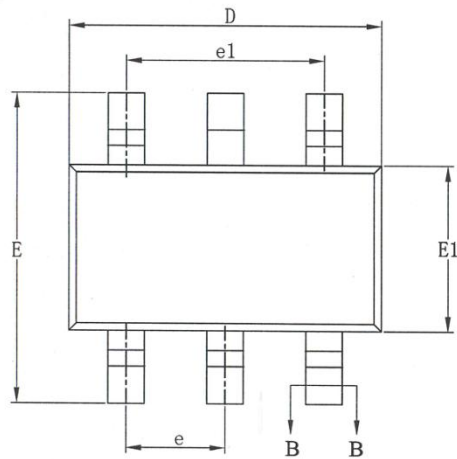
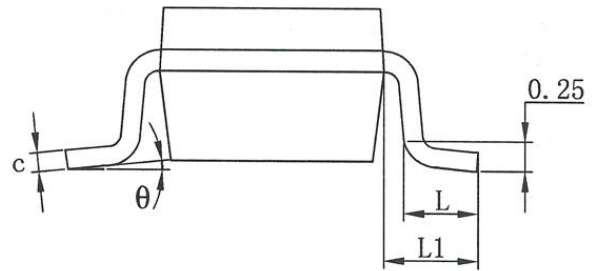
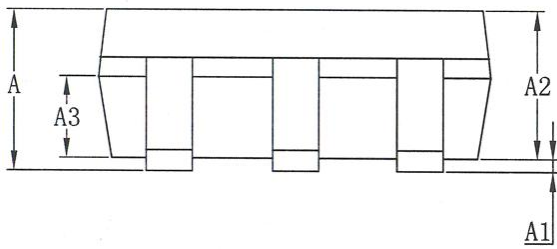

Dimension in mm			
Symbol	Min	Nom	Max
A	-	-	1.25
A1	0.03	-	0.11
A2	1.00	1.10	1.20
A3	0.60	0.65	0.70
b	0.33	-	0.41
b1	0.32	0.35	0.38
c	0.13	-	0.17
c 1	0.12	0.13	0.14
D	2.80	2.90	3.00
E	2.60	2.80	3.00
E1	1.50	1.60	1.70
e	0.95BSC		
L	0.30	-	0.60
L1	0.60REF		
θ	0	-	8°

Packing Information

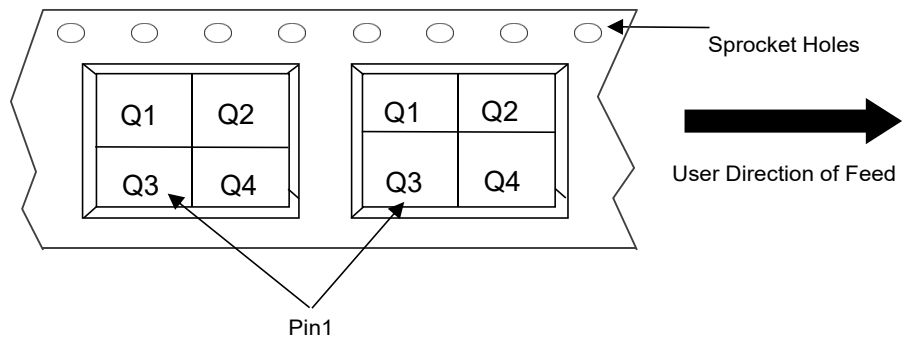
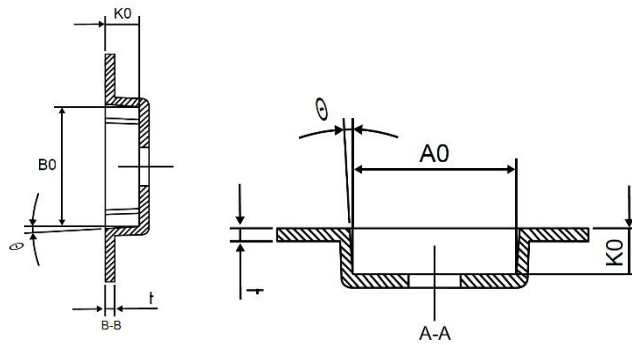
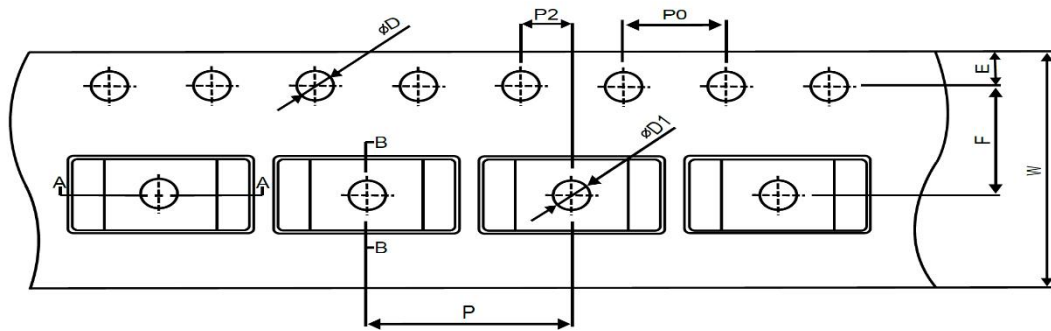

Package Type	A0 (mm)	B0 (mm)	K0 (mm)	P (mm)	P0 (mm)	W (mm)	Pin1 Quadrant	Quantity
SOT23-6	3.26	3.30	1.40	4.00	4.00	8.00	Q3	3000

Version History

Version	Date	Changes
Rev.1.0	2025-11-04	Initial release
Rev.1.1	2025-11-24	Updated Absolute Maximum Ratings

Disclaimer

MetaWells Co., Ltd. and all other MetaWells Co., Ltd. trademarks are the exclusive property of MetaWells Co., Ltd.. Any mention of additional trademarks or registered trademarks in this document is made in acknowledgment of their respective owners.

Without the consent of MetaWells Co., Ltd. , any modification to any part or subsection of the company's product specifications and datasheets is strictly prohibited in any form or manner. MetaWells Co., Ltd. reserves the rights to make changes of the content herein the document follow PCN procedure. Please refer to our website for latest document. It is recommended that customers obtain the latest version of relevant information and verify its timeliness and completeness before placing an order. All products are sold in accordance with the terms and conditions provided in the sales contract at the time of order confirmation, which includes warranty scope, intellectual property rights, and liability limitations.

During the sales period, MetaWells Co., Ltd. guarantees that the performance of the products will be in accordance with the company's standard warranty. The company utilizes testing and other quality control techniques to ensure the necessity to maintain this warranty. Except for government-mandated requirements, there is no need for special testing of measurement tables or other instruments.

Customers must acknowledge that our products are not intended or manufactured for use in life support systems or other high-risk activities or environments. The utilization of our products in such applications may lead to severe consequences, including personal injury, loss of life, property damage, or environmental harm. Our products are explicitly not warranted for deployment in high-risk activities, and we shall bear no responsibility towards customers or third parties for such usage.

MetaWells Co., Ltd. commits to providing technical support, assistance, advice, and information, in line with our current capabilities, including guidance related to the design, development, or debugging of purchased boards or other applications. However, we hereby disclaim all warranties concerning technical support, merchantability, or fitness for a particular purpose. We do not guarantee the error-free operation of boards or applications in conjunction with our support services, and we shall not be held liable for any consequences arising from the utilization of our support services.

Copyright© MetaWells Co., Ltd.

Website: www.MetaWells.com