

PM56005A-60P Datasheet

600V, 5A, 3Phase Intelligent Power Module

Version: Rev.1.0

Release Date: 2025-06-23

MetaWells Co., Ltd.

www.MetaWells.com.

FEATURES

- ◆ Built-in six 6A/600V fast recovery power MOSFET
- ◆ Built-in high-voltage gate driver circuit (HVIC)
- ◆ Built-in undervoltage protection
- ◆ Built-in bootstrap diode
- ◆ Fully compatible with 3.3V and 5V MCU interfaces, active-high logic
- ◆ Temperature sensing function
- ◆ Three independent negative DC terminals for inverter current sensing applications
- ◆ Low-EMI optimized design
- ◆ Insulation rating: 1500Vrms/min

APPLICATIONS

- ◆ Indoor and outdoor air conditioners
- ◆ Refrigerator compressors
- ◆ Exhaust fans
- ◆ Air purifiers
- ◆ Dishwasher pumps

MECHANICAL PROPERTIES

- ◆ Package: SOP23
- ◆ Encapsulation material: UL flammability classification rating 94V-0
- ◆ Pins: Dark tin-plated leads; solderability standard MIL-STD-202, Method 208



SOP23

ORDERING INFORMATION

ORDER NUMBER	Marking ID	Package	Description
PM56005A-60P	PM56005A 60PYMDNN	SOP-23	Halogen Free RoHS compliant in Tube, 640pcs/bag

MARKING INFORMATION

Marking	Package	Definition
PM56005A 60PYMDNN	SOP-23	Product code : PM56005A, Voltage/Package code : 60P Y : Year code M : Month code D : Day code NN: Serial Number

FUNCTION BLOCK DIAGRAM

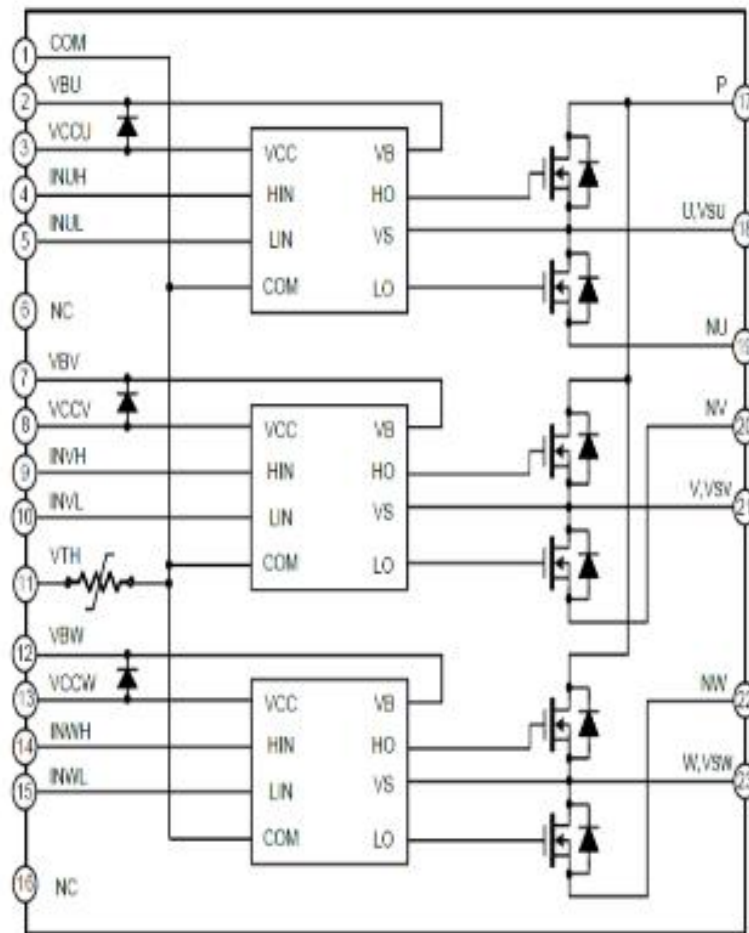

PIN CONFIGURATION

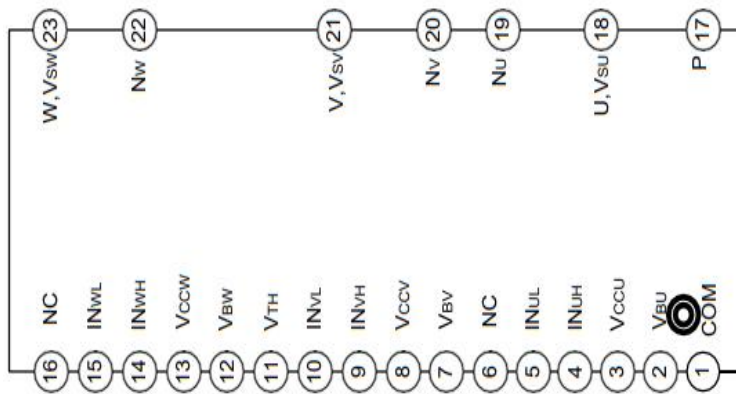

Terminal		Description
Pin No.	Name	
1	COM	Common ground
2	V _{BU}	U-phase high-side floating power supply voltage
3	V _{CCU}	U-phase high and low drive power supply voltage
4	IN _{UH}	U-phase high-side signal input
5	IN _{UL}	U-phase low-side signal input
6	NC	No connection
7	V _{BV}	V-phase high-side floating power supply voltage
8	V _{CCV}	V-phase high and low drive power supply voltage
9	IN _{VH}	V-phase high side signal input
10	IN _{VL}	V-phase low-side signal input
11	V _{TH}	Thermistor output
12	V _{BW}	W-phase high-side floating power supply voltage
13	V _{CCW}	W-phase high and low drive power supply voltage
14	IN _{WH}	W-phase high-side signal input
15	IN _{WL}	W-phase low-side signal input
16	NC	No connection
17	P	DC positive terminal
18	U, V _{SU}	U-phase output and high-side floating ground
19	NU	U-phase DC negative terminal
20	NV	V-phase DC negative terminal
21	V, V _{SV}	W-phase DC negative terminal
22	NW	W phase DC negative terminal
23	W, V _{SW}	W-phase output and high-side floating ground for W-phase drive

ABSOLUTE MAXIMUM RATINGS

T_A = 25°C unless otherwise specified

Symbol	Parameter	Rating	Unit
V _{PN}	Applied to P-N Power Voltage	600	V
I _{D25}	Continuous Drain Current per MOSFET (T _C = 25°C)	3.6	A
I _{D80}	Continuous Drain Current per MOSFET (T _C = 80°C)	2.4	A
I _{DP}	Peak Drain Current of a Single MOSFET, Pulse Width of Less Than 100µs at T _C = 25°C	6	A
V _{CC}	Control Supply Voltage	20	V
V _{BS}	High-Side Control Voltage	20	V
V _{IN}	Input Signal Voltage	-0.3~V _{CC} +0.3	V
V _{ISO}	Insulation Voltage: 60Hz Sine Wave, AC, 1 Minute, from Connecting Pin to Heat Sink	1500	V _{rms}

THERMAL CHARACTERISTICS

Symbol	Parameter	Rating	Unit
P _D	Maximum Power Dissipation (T _C = 25°C)	83	W
R _{θJC}	Thermal Resistance, Junction to Case	8.5	°C/W
T _C	Operating Case Temperature Range	-40~ +125	°C
T _J	Operating Junction Temperature Range	-40~ +150	°C
T _{STG}	Storage Temperature Range	-40 ~ +125	°C

RECOMMENDED OPERATING CONDITIONS

T_A = 25°C unless otherwise specified

Symbol	Parameter	Values			Unit
		Min	Typ	Max	
V _{PN}	Power Supply Voltage	-	360	480	V
V _{CC}	Control Supply Voltage	13.5	15	16.5	V
V _{BS}	High-Side Control Voltage	13.5	15	16.5	V
V _{IN (ON)}	Input Turn-On Threshold Voltage	3	-	V _{CC}	V
V _{IN (OFF)}	Input Turn-Off Threshold Voltage	0	-	0.8	V
T _{DEAD}	Dead Time to Prevent Short-Circuit in Bridge Arm V _{CC} = V _{BS} = 13.5~16.5V, T _J ≤ 150°C	1.0	-	-	µs
f _{PWM}	PWM Switching Frequency, T _J ≤ 150°C	-	15	-	kHz

ELECTRICAL CHARACTERISTICS

Inverter Section – Specifically for a Single Fast Recovery MOSFET

$T_A = 25^\circ\text{C}$, $V_{CC} = V_B = 15\text{V}$, $V_S = \text{COM} = 0$ unless otherwise specified.

Symbol	Parameter	Condition	Min	Typ	Max	Unit
BV_{DSS}	Drain-to-Source Breakdown Voltage (with Zero Gate Voltage)	$V_{IN} = 0\text{V}$, $I_D = 250\mu\text{A}^{(1)}$	600	-	-	V
I_{DSS}	Drain Current	$V_{IN} = 0\text{V}$, $V_{DS} = 500\text{V}$	-	-	1	μA
$R_{DS(ON)}$	Static Drain-to-Source On-Resistance	$V_{CC} = V_{BS} = 15\text{V}$, $V_{IN} = 5\text{V}$, $I_D = 1.2\text{A}$	-	1.7	2.0	Ω
V_{SD}	Forward Voltage of Drain-to-Source Diode	$V_{CC} = V_{BS} = 15\text{V}$, $V_{IN} = 0\text{V}$, $I_D = -1.2\text{A}$	-	-	1.2	V
t_{ON}	Switching Time	$V_{PN} = 250\text{V}$ $V_{CC} = V_{BS} = 15\text{V}$ $I_D = 1.2\text{A}$ $V_{IN} = 0\text{V} \sim 5\text{V}$ Inductive load ⁽²⁾	-	700	900	ns
t_{OFF}			-	170	300	ns
t_{RR}			-	87	-	ns
E_{ON}			-	70	-	μJ
E_{OFF}			-	10	-	μJ

Note:

- BV_{DSS} refers to the maximum voltage limit between the source and drain of each power MOSFET. In practical applications, considering the influence of stray inductance, V_{PN} voltage should be much lower than this value to ensure that the voltage applied to the MOSFET at any time does not exceed BV_{DSS} .
- t_{ON} and t_{OFF} include the internal transmission delay of the HVIC. The typical values listed are test values under laboratory test conditions and may vary in practical applications depending on the printed circuit board and circuitry used. For detailed definitions and test circuits of switching times, please refer to Figure 2 below.

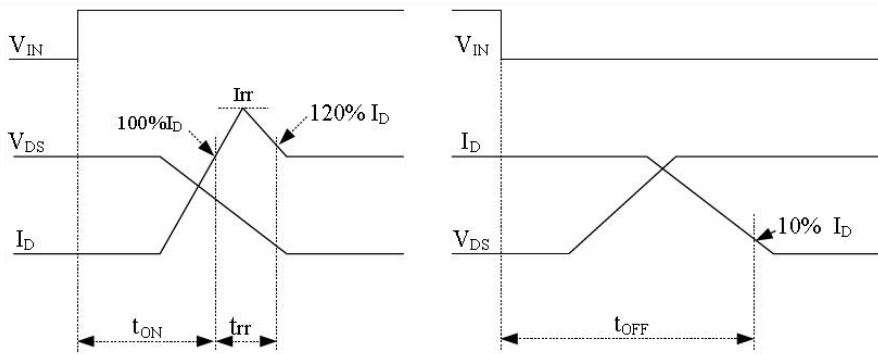

Figure 1 Definition of Switching Time

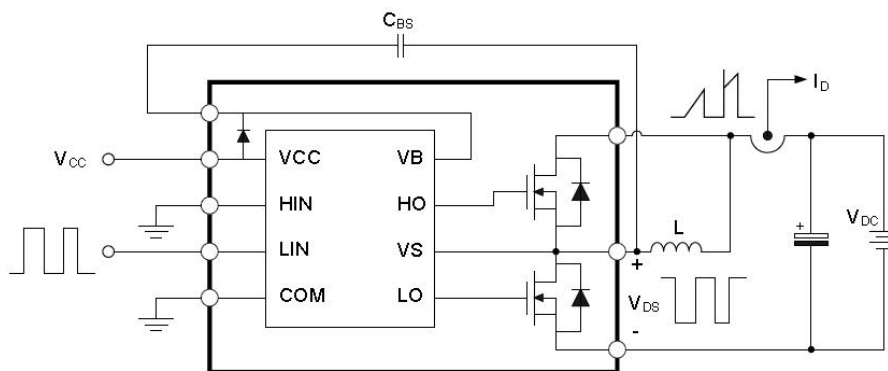

Figure 2 Switching time and low side of RBSOA test circuit

Control Part Single HVIC

Symbol	Parameter	Condition	Min	Typ	Max	Unit
V_{IH}	High-Level Conduction Threshold Voltage	(Logic high level, between input and COM)	3	-	-	V
V_{IL}	Low-Level Turn-Off Threshold Voltage	(Logic low level, between input and COM)	-	-	0.8	V
UV_{BSD}	High-Side Undervoltage Protection Action Voltage	Detection level ⁽¹⁾	7.2	8.2	9.0	V
UV_{BSR}	High-Side Undervoltage Protection Recovery Voltage	Reset level ⁽¹⁾	8.0	8.9	9.9	V
UV_{CCD}	Low-Side Undervoltage Protection Action Voltage	Detection level ⁽¹⁾	7.2	8.2	9.0	V
UV_{CCR}	Low-Side Undervoltage Protection Recovery Voltage	Reset level ⁽¹⁾	8.0	8.9	9.9	V
I_{QBS}	Static Current of V_{BS} Terminal	$V_{BS} = 15V, V_{IN} = 0V$ Between $V_{B(U)}-U, V_{B(V)}-V, V_{B(W)}-W$	-	-	100	μA
I_{QCC}	Static Current of V_{CC} Terminal	$V_{CC} = 15V, V_{IN} = 0V$, Between V_{CC} and COM	-	-	230	μA
I_{IN+}	High-Level Input Bias Current	$V_{IN} = 5V$, between input and COM	-	10	20	μA
I_{IN-}	Low-Level Input Bias Current	$V_{IN} = 0V$ between input and COM	-	-	2	μA

Note:

(1)The timing diagram of the high and low side undervoltage protection function is shown in Figure 3/Figure 4

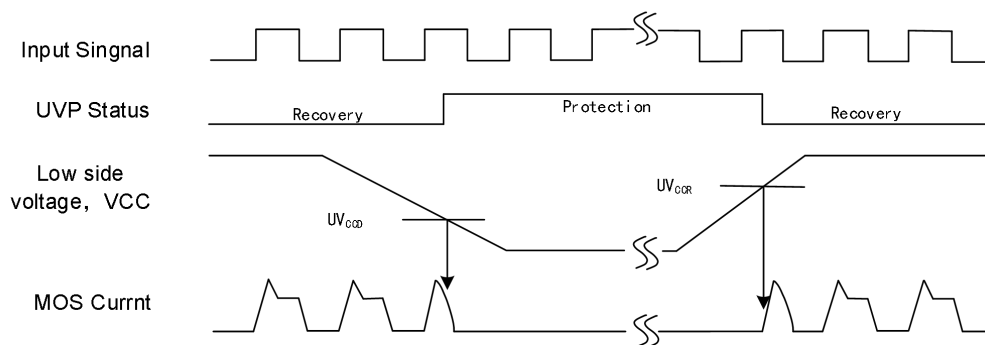

Figure 3 Undervoltage protection low side:

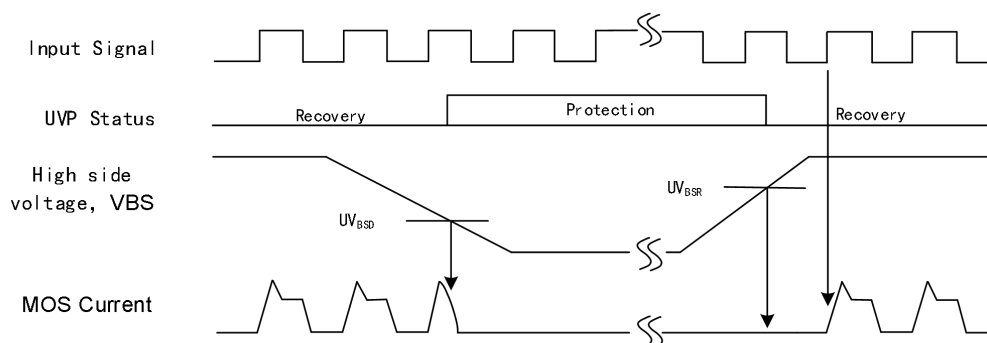

Figure 4 Undervoltage protection high side:

Strap Diode Section

Symbol	Parameter	Condition	Min	Typ	Max	Unit
V_F	Forward Voltage	$I_F = 0.5A, T_C = 25^\circ C$	-	-	1.5	V
t_{RR}	Reverse Recovery Time	$I_F = 0.5A, T_C = 25^\circ C$	-	-	50	ns

NTC (Negative Temperature Coefficient) Resistor

Symbol	Parameter	Condition	Min	Typ	Max	Unit
R_{TH}	Thermistor Resistance ⁽¹⁾	$T_{TH} = 25^\circ C$	-	48	-	K Ω
		$T_{TH} = 100^\circ C$	-	3.1	-	K Ω

Note:

(1) T_{TH} is the temperature of the thermistor itself. In the application circuit, the Vth pin is pulled up to VCC through a 7.50k Ω resistor. NTC tolerance $\pm 5\%$. If you need to test the shell temperature (T_C), please conduct experiments based on actual applications.

PHYSICAL DIMENSIONS-SOP-23

Unit:mm

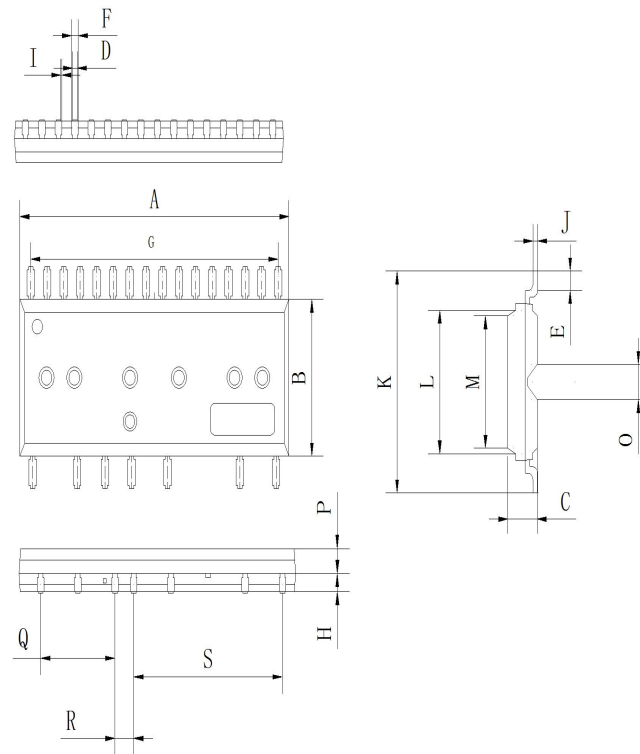

Symbol	Dimensions In Millimeters	
	Min.	Max.
A	28.80	29.20
B	11.80	12.20
C	3.05	3.25
D	0.50	0.70
E	1.05	1.75
F	0.75	1.05
G	26.37	26.97
H	1.15	1.45
I	0.00	0.15
J	0.40	0.60
K	16.70	17.30
L	10.80	11.20
M	9.90	10.30
O	2.58	2.78
P	1.70	2.00
Q	7.60	8.00
R	1.75	2.15
S	15.40	15.80

Disclaimer

MetaWells Co., Ltd. and all other MetaWells Co., Ltd. trademarks are the exclusive property of MetaWells Co., Ltd.. Any mention of additional trademarks or registered trademarks in this document is made in acknowledgment of their respective owners.

Without the consent of MetaWells Co., Ltd. , any modification to any part or subsection of the company's product specifications and datasheets is strictly prohibited in any form or manner. MetaWells Co., Ltd. reserves the right to modify datasheets and/or products, discontinue any product, or terminate services without prior notice. It is recommended that customers obtain the latest version of relevant information and verify its timeliness and completeness before placing an order. All products are sold in accordance with the terms and conditions provided in the sales contract at the time of order confirmation, which includes warranty scope, intellectual property rights, and liability limitations.

During the sales period, MetaWells Co., Ltd. guarantees that the performance of the products will be in accordance with the company's standard warranty. The company utilizes testing and other quality control techniques to ensure the necessity to maintain this warranty. Except for government-mandated requirements, there is no need for special testing of measurement tables or other instruments.

Customers must acknowledge that our products are not intended or manufactured for use in life support systems or other high-risk activities or environments. The utilization of our products in such applications may lead to severe consequences, including personal injury, loss of life, property damage, or environmental harm. Our products are explicitly not warranted for deployment in high-risk activities, and we shall bear no responsibility towards customers or third parties for such usage.

MetaWells Co., Ltd. commits to providing technical support, assistance, advice, and information, in line with our current capabilities, including guidance related to the design, development, or debugging of purchased boards or other applications. However, we hereby disclaim all warranties concerning technical support, merchantability, or fitness for a particular purpose. We do not guarantee the error-free operation of boards or applications in conjunction with our support services, and we shall not be held liable for any consequences arising from the utilization of our support services.

Copyright© MetaWells Co., Ltd.

Website: www.MetaWells.com