

PJ74LVC1G04 Datasheet

Single Inverter Gate In a SOT23-5 and SC70-5 Package

Version: Rev.1.0

Release Date: 2025-11-05

MetaWells Co., Ltd.

www.MetaWells.com

General Description

The PJ74LVC1G04 is a single inverter gate. The device is designed for 1.65 V to 5.5 V for V_{CC} operation, it can be driven from either 3.3 V or 5 V devices. This feature allows the use of these devices as translators in mixed 3.3 V and 5 V environments.

The PJ74LVC1G04 performs the Boolean function $Y = \overline{A}$ in positive logic.

The CMOS device has high output drive while maintaining low static power dissipation over a broad V_{CC} operating range.

The PJ74LVC1G04 is available in SOT23-5 and SC70-5 packages.

Features

- ◆ Wide Supply Voltage Range : 1.65 V to 5.5 V
- ◆ Max. T_{PD} of 3.3 ns at $V_{CC} = 3.3$ V
- ◆ Low Power Consumption, 10 μ A (Max. I_{CC})
- ◆ ± 24 mA Output Drive at $V_{CC} = 3.3$ V
- ◆ Latch-Up Performance Exceeds 100 mA Per JESD 78, Class II
- ◆ ESD Protection Exceeds JESD 22
 - 2000 V Human-Body Model (A114-A)
 - 1000 V Charged-Device Model (C101)
- ◆ Operating temperature Range : -40°C to 125°C
- ◆ Available Package : SOT23-5 and SC70-5

Simplified Schematic

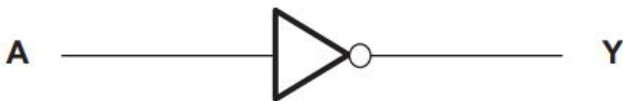

Applications

- ◆ Active Noise Cancellation (ANC)
- ◆ Blood Pressure Monitor
- ◆ Embedded PC
- ◆ Solid State Drive (SSD) : Client and Enterprise
- ◆ TV : LCD/Digital and High-Definition (HDTV)
- ◆ Tablet : Enterprise
- ◆ Video Analytics : Server
- ◆ Wireless Headset, Keyboard, and Mouse
- ◆ Power Supply : Telecom/Server AC/DC Controller

Ordering Information

Ordering Information

Order number	Marking ID	Package	MSL	Description
PJ74LVC1G04S5	A8 DNN	SOT23-5	Level-3	Halogen free RoHS compliant in T/R, 3,000 pcs/Reel
PJ74LVC1G04C5	A3 W	SC70-5	Level-3	Halogen free RoHS compliant in T/R, 3,000 pcs/Reel

Note:

(1) MetaWells can meet RoHS 2.0/REACH requirement. So most package types MetaWells offers only states halogen free, instead of lead free.

Marking Information

Marking	Package	Definition
A8 DNN	SOT23-5	A8: Product code D: Date code NN: Serial number
A3 W	SC70-5	A3: Product code W: Week code

Pin Configuration

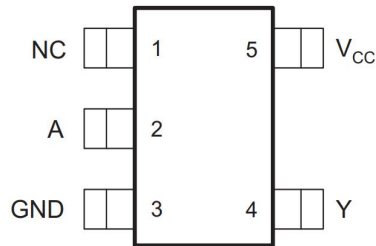

SOT23-5 and SC70-5 (Top View)

Pin Description

Pin		Function
Num	Name	
1	NC	No Connect
2	A	Data Input
3	GND	Ground
4	Y	Data Output
5	V _{CC}	Supply Power Input

Function Table

H = HIGH voltage level; L = LOW voltage level;

INPUT	OUTPUT
A	Y
L	H
H	L

Absolute Maximum Ratings

Over operating free-air temperature range (unless otherwise noted) ⁽¹⁾

Parameter	Symbol	Value	Units
Supply Voltage	V_{CC}	-0.5 to 6.5	V
Input Voltage	V_I	-0.5 to 6.5	V
Voltage range applied to any output in the high-impedance or power-off state ⁽²⁾	V_O	-0.5 to 6.5	V
Voltage range applied to any output in the high or low state ⁽²⁾⁽³⁾	V_O	-0.5 to $V_{CC}+0.5$	V
Input clamp current, $V_I < 0$	I_{IK}	-50	mA
Output clamp current, $V_O < 0$	I_{OK}	-50	mA
Continuous output current	I_O	± 50	mA
Storage temperature range	T_{STG}	-65 to 150	$^{\circ}C$
ESD HBM, ANSI/ESDA/JEDEC JS-001 ⁽⁴⁾	ESD_{HBM}	± 2000	V
ESD CDM, JESD22-C101 ⁽⁵⁾	ESD_{CDM}	± 1000	V

(1) Stresses beyond those listed under absolute maximum ratings may cause permanent damage to the device. These are stress ratings only, and functional operation of the device at these or any other conditions beyond those indicated under recommended operating conditions is not implied. Exposure to absolute-maximum-rated conditions for extended periods may affect device reliability.

(2) The input and output negative-voltage ratings may be exceeded if the input and output current ratings are observed.

(3) The value of V_{CC} is provided in the Recommended Operating Conditions table.

(4) JEDEC document JEP155 states that 500-V HBM allows safe manufacturing with a standard ESD control process.

(5) JEDEC document JEP157 states that 250-V CDM allows safe manufacturing with a standard ESD control process.

Recommended Operating Conditions

Parameter	Symbol	Test Conditions	Min	Typ	Max	Units
Supply voltage	V_{CC}	Operating	1.65		5.5	V
		Data retention only	1.5			
Input voltage	V_I		0		5.5	V
Output voltage	V_O				V_{CC}	V
High-level input voltage	V_{IH}	$V_{CC} = 1.65\text{ V to }1.95\text{ V}$	$0.65 \times V_{CC}$			V
		$V_{CC} = 2.3\text{ V to }2.7\text{ V}$	1.7			
		$V_{CC} = 3\text{ V to }3.6\text{ V}$	2			
		$V_{CC} = 4.5\text{ V to }5.5\text{ V}$	$0.7 \times V_{CC}$			
Low-level input voltage	V_{IL}	$V_{CC} = 1.65\text{ V to }1.95\text{ V}$			$0.35 \times V_{CC}$	V
		$V_{CC} = 2.3\text{ V to }2.7\text{ V}$			0.7	
		$V_{CC} = 3\text{ V to }3.6\text{ V}$			0.8	
		$V_{CC} = 4.5\text{ V to }5.5\text{ V}$			$0.3 \times V_{CC}$	
High-level output current	I_{OH}	$V_{CC} = 1.65\text{ V}$			-4	mA
		$V_{CC} = 2.3\text{ V}$			-8	
		$V_{CC} = 3\text{ V}$			-16	
		$V_{CC} = 3\text{ V}$			-24	
		$V_{CC} = 4.5\text{ V}$			-32	
Low-level output current	I_{OL}	$V_{CC} = 1.65\text{ V}$			4	mA
		$V_{CC} = 2.3\text{ V}$			8	
		$V_{CC} = 3\text{ V}$			16	
		$V_{CC} = 3\text{ V}$			24	
		$V_{CC} = 4.5\text{ V}$			32	
Input transition rise or fall rate	$\Delta T/\Delta V$	$V_{CC} = 1.8\text{ V} \pm 0.15\text{ V}, 2.5\text{ V} \pm 0.2\text{ V}$			20	ns/V
		$V_{CC} = 3.3\text{ V} \pm 0.3\text{ V}$			10	
		$V_{CC} = 5\text{ V} \pm 0.5\text{ V}$			5	
Operating temperature	T_A		-40		125	°C

Electrical Characteristics

Parameter	Symbol	Test Conditions	Min	Typ	Max	Units
High-level output voltage	V_{OH}	$V_{CC} = 1.65\sim 5.5\text{ V}, I_{OH} = -100\ \mu\text{A}$	$V_{CC}-0.1$			V
		$V_{CC} = 1.65\text{ V}, I_{OH} = -4\text{ mA}$	1.2			
		$V_{CC} = 2.3\text{ V}, I_{OH} = -8\text{ mA}$	1.9			
		$V_{CC} = 3\text{ V}, I_{OH} = -16\text{ mA}$	2.4			
		$V_{CC} = 3\text{ V}, I_{OH} = -24\text{ mA}$	2.3			
		$V_{CC} = 4.5\text{ V}, I_{OH} = -32\text{ mA}$	3.8			
Low-level output voltage	V_{OL}	$V_{CC} = 1.65\sim 5.5\text{ V}, I_{OL} = 100\ \mu\text{A}$			0.1	V
		$V_{CC} = 1.65\text{ V}, I_{OL} = 4\text{ mA}$			0.45	
		$V_{CC} = 2.3\text{ V}, I_{OL} = 8\text{ mA}$			0.3	
		$V_{CC} = 3\text{ V}, I_{OL} = 16\text{ mA}$			0.4	
		$V_{CC} = 3\text{ V}, I_{OL} = 24\text{ mA}$			0.55	
		$V_{CC} = 4.5\text{ V}, I_{OL} = 32\text{ mA}$			0.55	
Input leakage current	I_L	$V_{IN} = 5.5\text{ V or GND}, V_{CC} = 0\sim 5.5\text{ V}$			± 5	μA
Power off leakage current	I_{OFF}	$V_{IN} \text{ or GND}, V_{CC} = 0\sim 5.5\text{ V}$			± 10	μA
Quiescent supply current	I_Q	$V_{IN} = V_{CC} \text{ or GND}, I_{OUT} = 0,$ $V_{CC} = 1.65\sim 5.5\text{ V}$			10	μA
Additional quiescent supply current per input pin	ΔI_Q	$V_{CC} = 3\sim 5.5\text{ V},$ one input at $V_{CC}-0.6\text{ V},$ other input at $V_{CC} \text{ or GND}$			500	μA

Switching Characteristics

Parameter	Symbol	Test Conditions	Min	Typ	Max	Units
Propagation delay from input (A) to output (Y)	T_{PD}	$V_{CC} = 1.8\text{ V} \pm 0.15\text{ V}$	$C_L = 15\text{ pF}$ $R_L = 1\text{ M}\Omega$			6.4
		$V_{CC} = 2.5\text{ V} \pm 0.2\text{ V}$				4.2
		$V_{CC} = 3.3\text{ V} \pm 0.3\text{ V}$				3.3
		$V_{CC} = 5\text{ V} \pm 0.5\text{ V}$				3.1
			2			nS
			1			nS
			0.7			nS
			0.7			nS

Typical Performance Characteristics

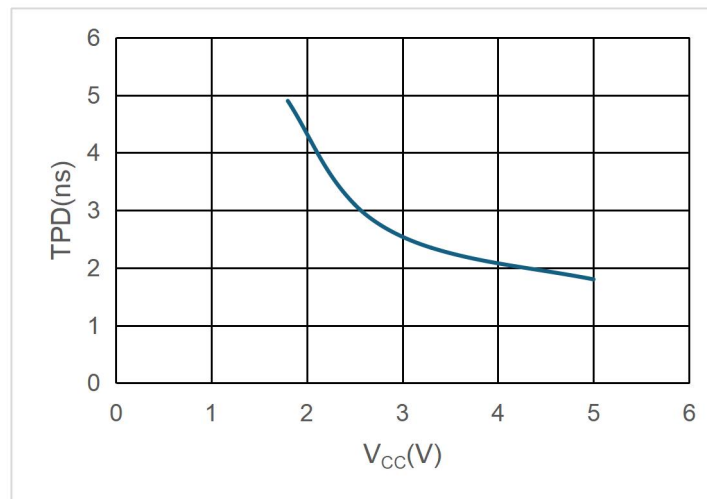
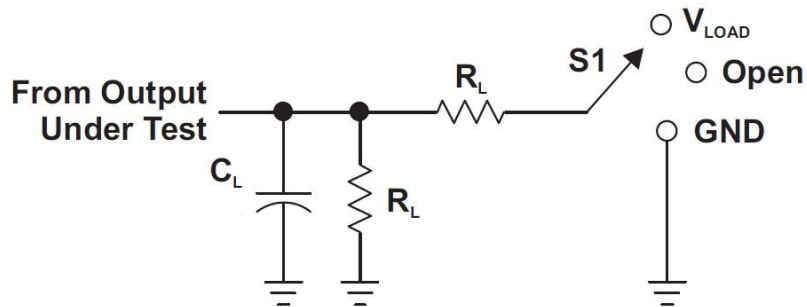

Figure 1. T_{PD} across V_{CC} at 25°C

Parameter Measurement Information



LOAD CIRCUIT

V_{CC}	INPUTS		V_M	C_L	R_L
	V_I	t_r/t_f			
1.8 V \pm 0.15 V	V_{CC}	$\cong 2$ ns	$V_{CC}/2$	15 pF	1 M Ω
2.5 V \pm 0.2 V	V_{CC}	$\cong 2$ ns	$V_{CC}/2$	15 pF	1 M Ω
3.3 V \pm 0.3 V	3 V	$\cong 2.5$ ns	1.5 V	15 pF	1 M Ω
5 V \pm 0.5 V	V_{CC}	$\cong 2.5$ ns	$V_{CC}/2$	15 pF	1 M Ω

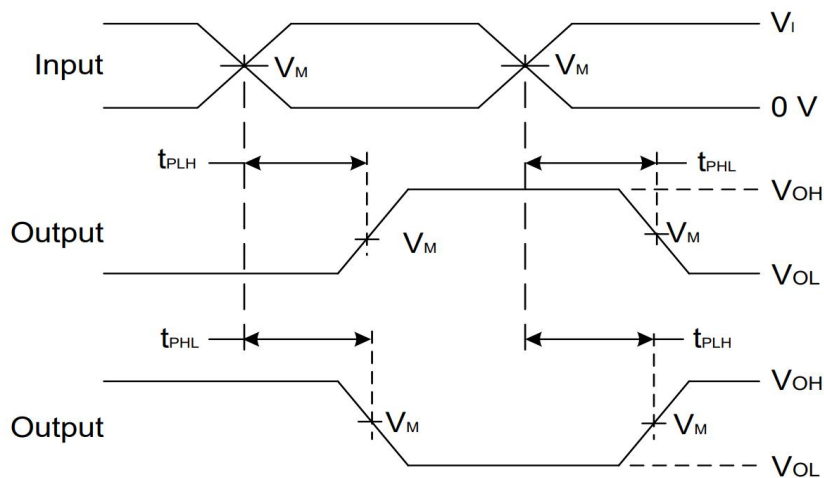

**Figure 2. Voltage waveform propagation delay times,
Inverting and non-inverting outputs**

Notes:

- (1) C_L includes probe and jig capacitance
- (2) All input pulses and supplied at pulse repetition rate ≤ 10 MHz.
- (3) The Inputs are measured separately one transition per measurement
- (4) t_{PLH} and t_{PHL} are the same as t_{PD}

Package Outline Dimension-SOT23-5

SOT23-5 Unit (mm)

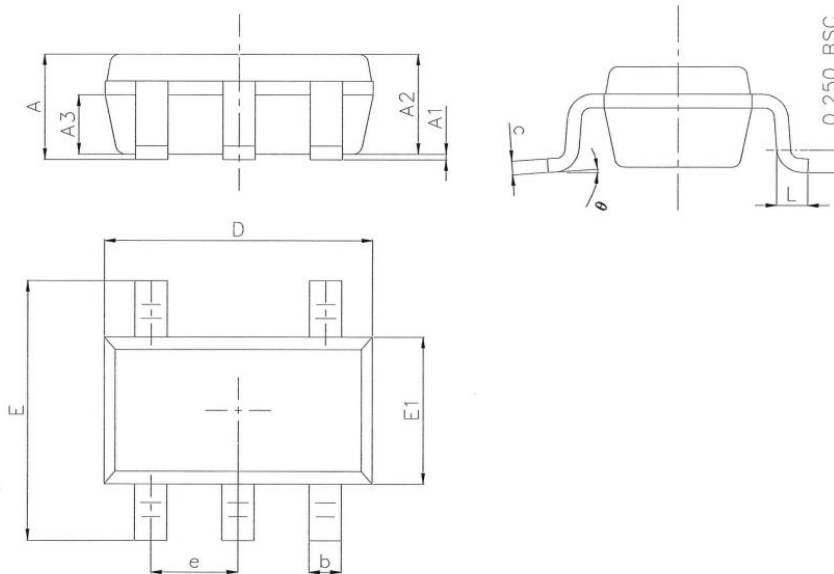

Symbol	Dimension in mm		
	Min.	Nom.	Max.
A	1.050	1.150	1.250
A1	0.000	0.060	0.100
A2	1.000	1.100	1.200
A3	0.550	0.650	0.750
D	2.820	2.920	3.020
E1	1.510	1.610	1.700
E	2.650	2.800	2.950
b	0.300	0.400	0.500
e	0.950BSC		
θ	0°	4°	8°
L	0.300	0.420	0.570
c	0.100	0.152	0.200

Package Outline Dimension-SC70-5

SC70-5 Unit (mm)

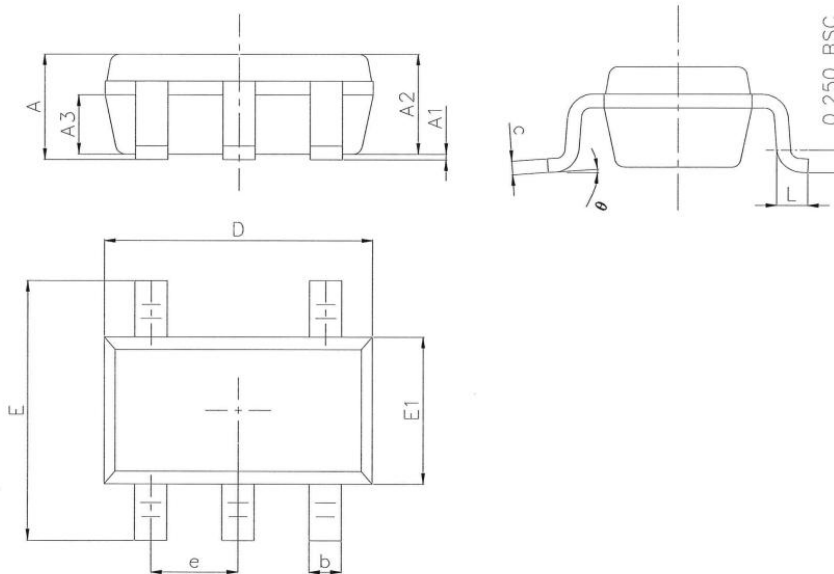

Symbol	Dimension in mm		
	Min.	Nom.	Max.
A	0.90	0.95	1.00
A1	0.00	0.05	0.10
A2		0.9	
A3		0.55	
D	2.00	2.10	2.20
E1	1.15	1.25	1.35
E	2.00	2.10	2.20
b	0.15	0.225	0.30
e	0.65BSC		
θ	0°	4°	8°
L	0.26	0.35	0.46
c	0.10	0.15	0.20

Packing information

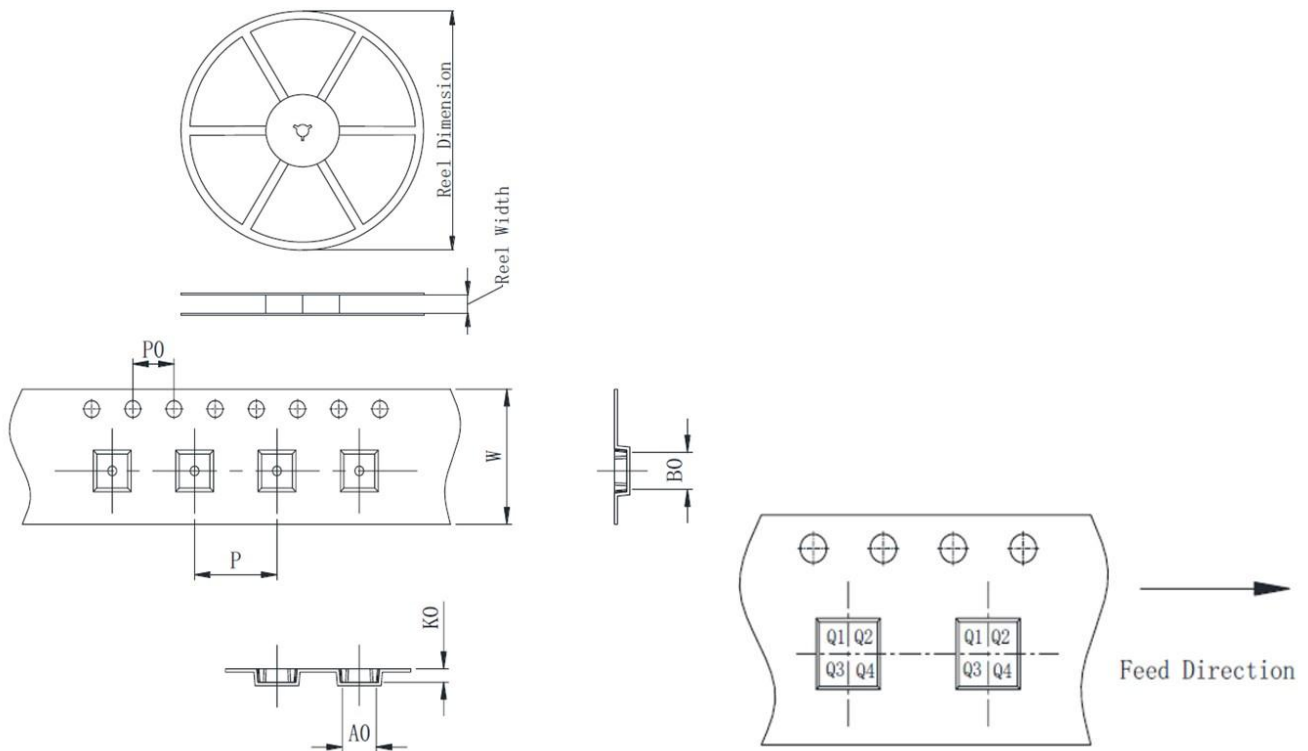

Package type	Reel size	Reel dimension (±3.0mm)	Reel width (±1.0mm)	A0 (±0.1mm)	B0 (±0.1mm)	K0 (±0.1mm)	P (±0.1mm)	P0 (±0.1mm)	W (±0.3mm)	Pin1
SOT23-5	7'	180	8.4	3.23	3.17	1.32	4.0	4.0	8.0	Q3
SC70-5	7'	180	8.4	3.23	3.17	1.32	4.0	4.0	8.0	Q3

Version History

Version	Date	Changes
Rev.1.0	2025-11-05	Initial release

Disclaimer

MetaWells Co., Ltd. and all other MetaWells Co., Ltd. trademarks are the exclusive property of MetaWells Co., Ltd.. Any mention of additional trademarks or registered trademarks in this document is made in acknowledgment of their respective owners.

Without the consent of MetaWells Co., Ltd. , any modification to any part or subsection of the company's product specifications and datasheets is strictly prohibited in any form or manner. MetaWells Co., Ltd. reserves the right to modify datasheets and/or products, discontinue any product, or terminate services without prior notice. It is recommended that customers obtain the latest version of relevant information and verify its timeliness and completeness before placing an order. All products are sold in accordance with the terms and conditions provided in the sales contract at the time of order confirmation, which includes warranty scope, intellectual property rights, and liability limitations.

During the sales period, MetaWells Co., Ltd. guarantees that the performance of the products will be in accordance with the company's standard warranty. The company utilizes testing and other quality control techniques to ensure the necessity to maintain this warranty. Except for government-mandated requirements, there is no need for special testing of measurement tables or other instruments.

Customers must acknowledge that our products are not intended or manufactured for use in life support systems or other high-risk activities or environments. The utilization of our products in such applications may lead to severe consequences, including personal injury, loss of life, property damage, or environmental harm. Our products are explicitly not warranted for deployment in high-risk activities, and we shall bear no responsibility towards customers or third parties for such usage.

MetaWells Co., Ltd. commits to providing technical support, assistance, advice, and information, in line with our current capabilities, including guidance related to the design, development, or debugging of purchased boards or other applications. However, we hereby disclaim all warranties concerning technical support, merchantability, or fitness for a particular purpose. We do not guarantee the error-free operation of boards or applications in conjunction with our support services, and we shall not be held liable for any consequences arising from the utilization of our support services.

Copyright© MetaWells Co., Ltd. 2024

Website : www.MetaWells.com