

GENERAL DESCRIPTION

The PJ85431 is a 2-channel digital temperature sensor with ±1°C accuracy. Temperature data can be read out directly via SMBus interface by MCU or SOC chip.

PJ85431 has two independent channels : 1 x remote and 1 x local. The remote channel could be connected to an external Diode, BJT transistor (diode-connected mode), or parasitic PNP BJT transistor inside the CPU, GPU, FPGA or SOC chip. Based on this, this chip can be used to monitor CPU, GPU, MCU, SOC, FPGA or DSP chip die and case temperature.

Each chip is calibrated in factory before shipment to customers. There is no need re-calibration anymore for ±1°C accuracy. It includes a band-gap circuit, an analog to digital converter (ADC), a calibration unit with non-volatile memory and a digital interface block.

It integrates a 12-bit ADC, which can offer 0.0625°C resolution. The maximum temperature readout range can be extended from -64°C to 191°C by setting configuration1 register.

It has 2 logic output pin (/ALERT and /THERM) with open drain structure, which are active low as default. Also /ALERT pin can be configured as /THERM2 pin.

Available Package : MSOP-8P and DFN3x3-8.

FEATURES

- ◆ Operation Voltage : 2.7 V to 5.5 V
- ◆ Average Quiescent Current : 16 µA (Typ.) at 0.0625 con/s, V_{CC} = 3.3 V
- ◆ Shutdown Current : 3.0 µA (Typ.)
- ◆ Temperature Accuracy without calibration for each channel : ±1°C from 0°C to 100°C
- ◆ 12 bit ADC for 0.0625°C resolution
- ◆ Digital interface compatible with SMBus and I²C
- ◆ Temperature Range up to from -64°C to 191°C by setting RANGE bit as “1”
- ◆ Programmable high/low-limit ALERT and THERM Temperature with Hysteresis
- ◆ Automatic beta compensation, Serial Resistance Cancellation, N-Factor correction and Thermal Diode Fault Detection for each remote channel
- ◆ Independent Remote and Local Temperature Sensing Channel
- ◆ Support SMBus ALERT Response Address
- ◆ Multiple Slave address options
- ◆ Temperature Range: -40°C to 125°C

APPLICATIONS

- ◆ Desktop & Notebook Computer
- ◆ Telecom, Industrial and Medical Equipments
- ◆ Servers

PIN CONFIGURATION

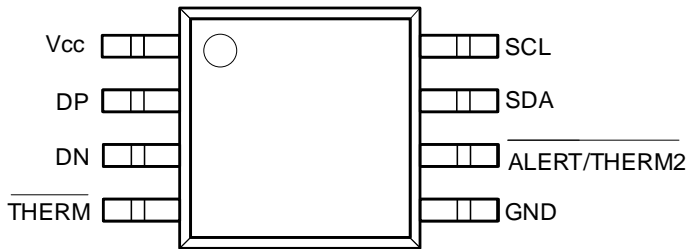
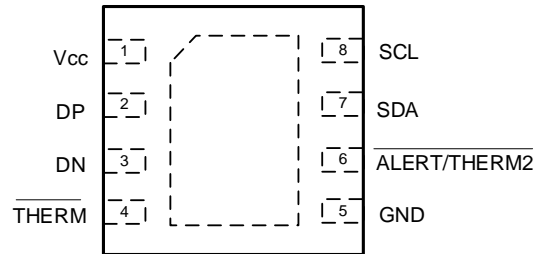
MSOP-8P (TOP VIEW)

DFN3x3-8 (TOP VIEW)

FUNCTIONAL PIN DESCRIPTION

TERMINAL		DESCRIPTION
NUMBER	NAME	
1	Vcc	Power supply input pin , using 0.1 μF low ESR ceramic capacitor to ground
2	DP	Remote sensor positive input pin , it could be positive node of Diode, or BJT transistor (diode-connected mode). It is recommended to use 100 pF bypass capacitor plus serial resistor ($R_s = 50 \text{ ohm}$) to remove noise between DP and DN pin.
3	DN	Remote sensor negative input pin , it could be negative node of Diode, or BJT transistor (diode-connected mode). It is recommended to use 100 pF bypass capacitor plus serial resistor ($R_S = 50 \text{ ohm}$) to remove noise between DP and DN pin.
4	/THERM	Open drain output with active low. Need a pull-up resistor to Vcc. For PJ85431P The resistor value determinates slave address. If the measured temperature exceeds THERM-limit (programmable by user), this pin will be activated. This pin can be used to control fan on/off.
5	GND	Ground pin.
6	/ALERT, /THERM2	Open drain output with active low. Need a pull-up resistor to Vcc. If the measured temperature drops below the low-limit or exceeds high-limit, this pin will be activated. Also this pin can be used as 2 nd THERM pin.
7	SDA	Digital interface data input or output pin, need a pull-up resistor to Vcc.
8	SCL	Digital interface clock input pin , need a pull-up resistor to Vcc.

**±1°C Remote and Local Temperature Sensor
with Digital Interface
In a MSOP-8P and DFN3x3-8 Package**

ORDERING INFORMATION

Order PN	Slave Address (R/W) ⁽²⁾	Accuracy	Green ⁽¹⁾	Package	Marking ID	Packing	MPQ	Operation Temperature
PJ85431M	0x99/98	±1°C	Halogen free	MSOP-8P	A1 YM DNN	Tape & Reel	3,000	-40°C ~+125°C
PJ85431AM	0x91/90	±1°C	Halogen free	MSOP-8P	AA YM DNN	Tape & Reel	3,000	-40°C ~+125°C
PJ85431BM	0x93/92	±1°C	Halogen free	MSOP-8P	AB YM DNN	Tape & Reel	3,000	-40°C ~+125°C
PJ85431CM	0x95/94	±1°C	Halogen free	MSOP-8P	AC YM DNN	Tape & Reel	3,000	-40°C ~+125°C
PJ85431DM	0x97/96	±1°C	Halogen free	MSOP-8P	AD YM DNN	Tape & Reel	3,000	-40°C ~+125°C
PJ85431EM	0x9B/9A	±1°C	Halogen free	MSOP-8P	AE YM DNN	Tape & Reel	3,000	-40°C ~+125°C
PJ85431FM	0x9D/9C	±1°C	Halogen free	MSOP-8P	AF YM DNN	Tape & Reel	3,000	-40°C ~+125°C
PJ85431GM	0x9F/9E	±1°C	Halogen free	MSOP-8P	AG YM DNN	Tape & Reel	3,000	-40°C ~+125°C
PJ85431PM	XXX1_100(W/R)	±1°C	Halogen free	MSOP-8P	AH YM DNN	Tape & Reel	3,000	-40°C ~+125°C
PJ85431PAM	XXX1_000(W/R)	±1°C	Halogen free	MSOP-8P	AJ YM DNN	Tape & Reel	3,000	-40°C ~+125°C
PJ85431PBM	XXX1_001(W/R)	±1°C	Halogen free	MSOP-8P	AK YM DNN	Tape & Reel	3,000	-40°C ~+125°C
PJ85431PCM	XXX1_010(W/R)	±1°C	Halogen free	MSOP-8P	AL YM DNN	Tape & Reel	3,000	-40°C ~+125°C
PJ85431PDM	XXX1_011(W/R)	±1°C	Halogen free	MSOP-8P	AM YM DNN	Tape & Reel	3,000	-40°C ~+125°C
PJ85431PEM	XXX1_101(W/R)	±1°C	Halogen free	MSOP-8P	AN YM DNN	Tape & Reel	3,000	-40°C ~+125°C
PJ85431PFM	XXX1_110(W/R)	±1°C	Halogen free	MSOP-8P	AP YM DNN	Tape & Reel	3,000	-40°C ~+125°C
PJ85431PGM	XXX1_111(W/R)	±1°C	Halogen free	MSOP-8P	AQ YM DNN	Tape & Reel	3,000	-40°C ~+125°C
PJ85431QW	0x99/98	±1°C	Halogen free	DFN3x3-8	A1 YM DNN	Tape & Reel	3,000	-40°C ~+125°C
PJ85431AQW	0x91/90	±1°C	Halogen free	DFN3x3-8	AA YM DNN	Tape & Reel	3,000	-40°C ~+125°C
PJ85431BQW	0x93/92	±1°C	Halogen free	DFN3x3-8	AB YM DNN	Tape & Reel	3,000	-40°C ~+125°C
PJ85431CQW	0x95/94	±1°C	Halogen free	DFN3x3-8	AC YM DNN	Tape & Reel	3,000	-40°C ~+125°C
PJ85431DQW	0x97/96	±1°C	Halogen free	DFN3x3-8	AD YM DNN	Tape & Reel	3,000	-40°C ~+125°C

**±1°C Remote and Local Temperature Sensor
with Digital Interface
In a MSOP-8P and DFN3x3-8 Package**

Order PN	Slave Address (R/W) ⁽²⁾	Accuracy	Green ⁽¹⁾	Package	Marking ID	Packing	MPQ	Operation Temperature
PJ85431EQW	0x9B/9A	±1°C	Halogen free	DFN3x3-8	AE YM DNN	Tape & Reel	3,000	-40°C ~+125°C
PJ85431FQW	0x9D/9C	±1°C	Halogen free	DFN3x3-8	AF YM DNN	Tape & Reel	3,000	-40°C ~+125°C
PJ85431GQW	0x9F/9E	±1°C	Halogen free	DFN3x3-8	AG YM DNN	Tape & Reel	3,000	-40°C ~+125°C
PJ85431PQW	XXX1_100(W/R)	±1°C	Halogen free	DFN3x3-8	AH YM DNN	Tape & Reel	3,000	-40°C ~+125°C
PJ85431PAQW	XXX1_000(W/R)	±1°C	Halogen free	DFN3x3-8	AJ YM DNN	Tape & Reel	3,000	-40°C ~+125°C
PJ85431PBQW	XXX1_001(W/R)	±1°C	Halogen free	DFN3x3-8	AK YM DNN	Tape & Reel	3,000	-40°C ~+125°C
PJ85431PCQW	XXX1_010(W/R)	±1°C	Halogen free	DFN3x3-8	AL YM DNN	Tape & Reel	3,000	-40°C ~+125°C
PJ85431PDQW	XXX1_011(W/R)	±1°C	Halogen free	DFN3x3-8	AM YM DNN	Tape & Reel	3,000	-40°C ~+125°C
PJ85431PEQW	XXX1_101(W/R)	±1°C	Halogen free	DFN3x3-8	AN YM DNN	Tape & Reel	3,000	-40°C ~+125°C
PJ85431PFQW	XXX1_110(W/R)	±1°C	Halogen free	DFN3x3-8	AP YM DNN	Tape & Reel	3,000	-40°C ~+125°C
PJ85431PGQW	XXX1_111(W/R)	±1°C	Halogen free	DFN3x3-8	AQ YM DNN	Tape & Reel	3,000	-40°C ~+125°C

- (1) Metawells can meet RoHS 2.0/REACH requirement. So most package types Metawells offers only states halogen free, instead of lead free.
- (2) For PJ85431P, Slave Address high 3bit is XXX, which means that the address of I²C is determined by the external pull-up resistance of THERM pin. For specific I²C address, please refer to 1.6.1 Slave Address.

MARKING INFORMATION

Marking	Package	Definition
Ax YM DNN	MSOP-8P	Ax: Product code Y: Year code M: Month code D: Day code NN: Serial No.
Ax YM DNN	DFN3x3-8	Ax: Product code Y: Year code M: Month code D: Day code NN: Serial No.

APPLICATION SCHEMATIC

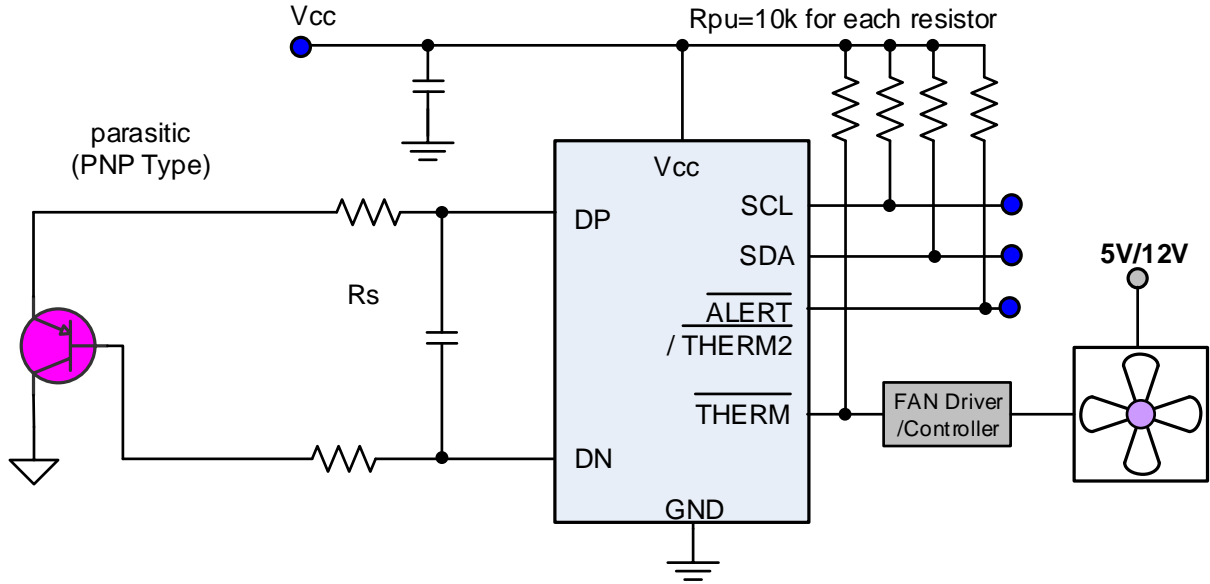

FUNCTION BLOCK

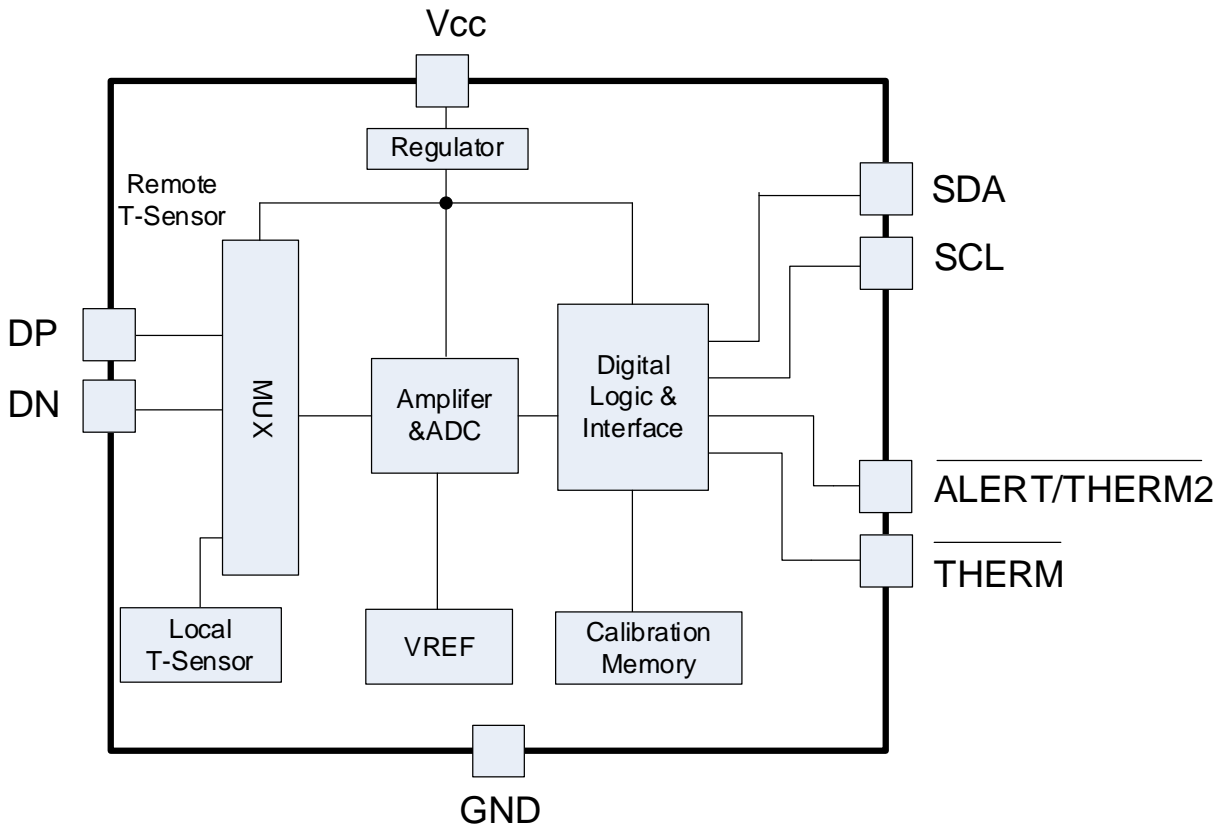

±1°C Remote and Local Temperature Sensor with Digital Interface In a MSOP-8P and DFN3x3-8 Package

ABSOLUTE MAXIMUM RATINGS

Over operating free-air temperature range (unless otherwise noted) ⁽¹⁾

PARAMETER		MIN	MAX	Unit
Supply Voltage	V _{CC} to GND	-0.3	V _{CC} +1.0	V
SDA, SCL Voltage	V _{SDA} /V _{SCL} to GND	-0.3	V _{CC} +1.0	V
DP Voltage	V _{DP} to GND	-0.3	V _{CC} +0.3	V
DN Voltage	V _{DN} to GND	-0.3	V _{CC} +0.3	V
/THERM, /ALERT Voltage	V _{THERM} /V _{ALERT} to GND	-0.3	V _{CC} +1.0	V
Operating junction temperature range	T _J	-50	150	°C
Storage Temperature Range	T _{STG}	-65	150	°C
Lead Temperature (Soldering, 10 Seconds)	T _{LEAD}	260		°C

(1) Stresses beyond those listed under **absolute maximum ratings** may cause permanent damage to the device. These are stress ratings only, and functional operation of the device at these or any other conditions beyond those indicated under **recommended operating conditions** is not implied. Exposure to absolute-maximum-rated conditions for extended periods may affect device reliability.

HANDLING RATINGS

PARAMETER	DEFINITION	MIN	MAX	UNIT
ESD ⁽¹⁾	Human Body Model (HBM) ESD stress voltage ⁽²⁾	-4	4	kV
	Charged Device Model (CDM) ESD stress voltage ⁽³⁾ , all pins	-1	1	kV

(1) Electrostatic discharge (ESD) to measure device sensitivity and immunity to damage caused by assembly line electrostatic discharges into the device.

(2) Level listed above is the passing level per ANSI, ESDA, and JEDEC JS-001. JEDEC document JEP155 states that 500-V HBM allows safe manufacturing with a standard ESD control process.

(3) Level listed above is the passing level per EIA-JEDEC JESD22-C101. JEDEC document JEP157 states that 250-V CDM allows safe manufacturing with a standard ESD control process.

RECOMMENDED OPERATING CONDITIONS

PARAMETER		MIN	TYP	MAX	UNIT
V _{CC}	Supply Voltage	2.7		5.5	V
T _A	Operating Ambient temperature	-40		125	°C

±1°C Remote and Local Temperature Sensor with Digital Interface In a MSOP-8P and DFN3x3-8 Package

ELECTRICAL CHARACTERISTICS

Test Condition: $V_{CC} = 3.3\text{ V}$, unless otherwise specified, all limits are 100% test at $T_A = 25^\circ\text{C}$. ⁽¹⁾

PARAMETER		TEST CONDITIONS	MIN	TYP	MAX	UNIT	
V_{CC}	Supply voltage range		2.7		5.5	V	
T_{RAC}	Temperature Accuracy (Remote Channel)	$T_A = 0$ to 100°C	-1.0		1.0	$^\circ\text{C}$	
		$T_A = -40$ to 125°C	-2.5		2.5	$^\circ\text{C}$	
T_{LAC}	Temperature Accuracy (Local Channel)	$T_A = 0$ to 100°C	-1.0		1.0	$^\circ\text{C}$	
		$T_A = -40$ to 125°C	-1.8		1.8	$^\circ\text{C}$	
I_{AOC}	Average Operating Current	$V_{IN} = 3.3\text{ V}$, 0.0625 con/s		13	16	μA	
		$V_{IN} = 5.0\text{ V}$, 0.0625 con/s		21	25	μA	
I_{SD}	Shutdown Current	Enable STB bit, force SDA/SCL to V_{CC} or GND		3	6	μA	
V_{ODL}	Open Drain Output Low Voltage	/ALERT, /THERM pin, sink 5mA	0		0.2	V	
I_{ODL}	Open Drain Leakage	/ALERT, /THERM pin Leakage	-1.0		1.0	μA	
T_{CON}	Conversion time	Local Channel		15		mS	
		Remote Channel	BC ⁽²⁾ enable, SRC ⁽²⁾ enable		120		mS
			BC enable, SRC disable		47		mS
			BC disable, SRC enable		90		mS
			BC disable, SRC disable		41		mS
DIGITAL INTERFACE							
C_{IL}	Logic Input Capacitance	SDA, SCL pin		3		pF	
V_{IH}	Logic Input High Voltage	SDA, SCL pin	1.4		$V_{CC}+0.3$	V	
V_{IL}	Logic Input Low Voltage	SDA, SCL pin	-0.3		0.8	V	
I_{INL}	Logic Input Current	SDA, SCL pin	-1.0		1.0	μA	
I_{OLS}	Logic Output Sink Current	SDA, /ALERT, /THERM pin, forced 0.2 V		5		mA	
f_{CLK}	SCL frequency		10		400	KHz	
t_{TOUT}	Timeout of detecting clock low period time			30		mS	
t_{LOW}	Clock low period time		1300			nS	
t_{HIGH}	Clock high period time		600			nS	
t_{BUF}	Bus free time	Between Stop and Start condition	1200			nS	
$t_{HD:STA}$	Hold time after Start condition		600			nS	
$t_{SU:STA}$	Repeated Start condition setup time		600			nS	
$t_{SU:STO}$	Stop condition setup time		600			nS	
$t_{HD:DAT}$	Data Hold time		100			nS	
$t_{SU:DAT}$	Data Setup time		100			nS	
t_F	Clock/Data fall time				300	nS	
t_R	Clock/Data rise time				1000	nS	

(1) All devices are 100% production tested at $T_A = +25^\circ\text{C}$; all specifications over the automotive temperature range is guaranteed by design, not production tested.

(2) BC means beta compensation; SRC means Series Resistance Cancellation.

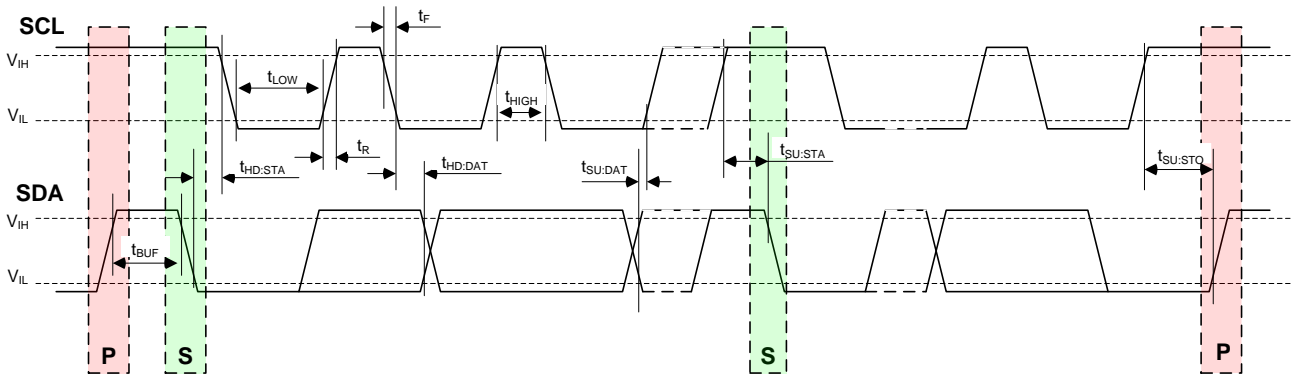

Figure-1. SMBus Timing Diagram

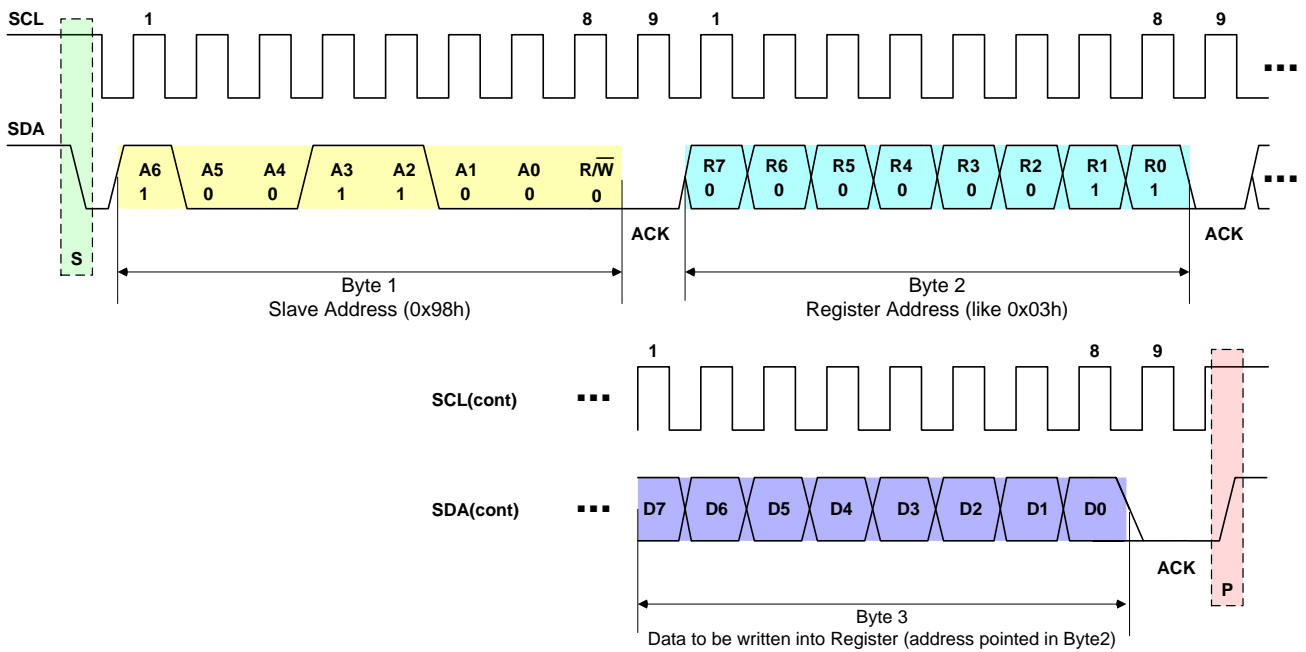

Figure-2. SMBus 1-byte Write Timing Diagram

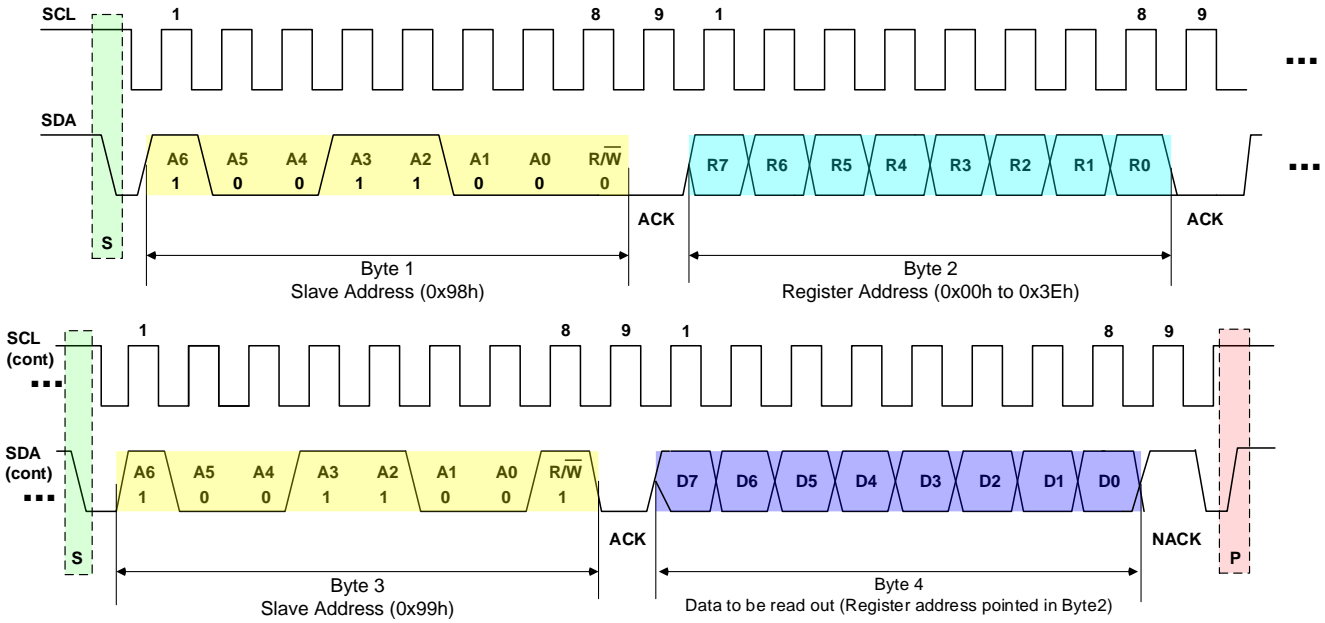

Figure-3. SMBus 1-byte Read Timing Diagram

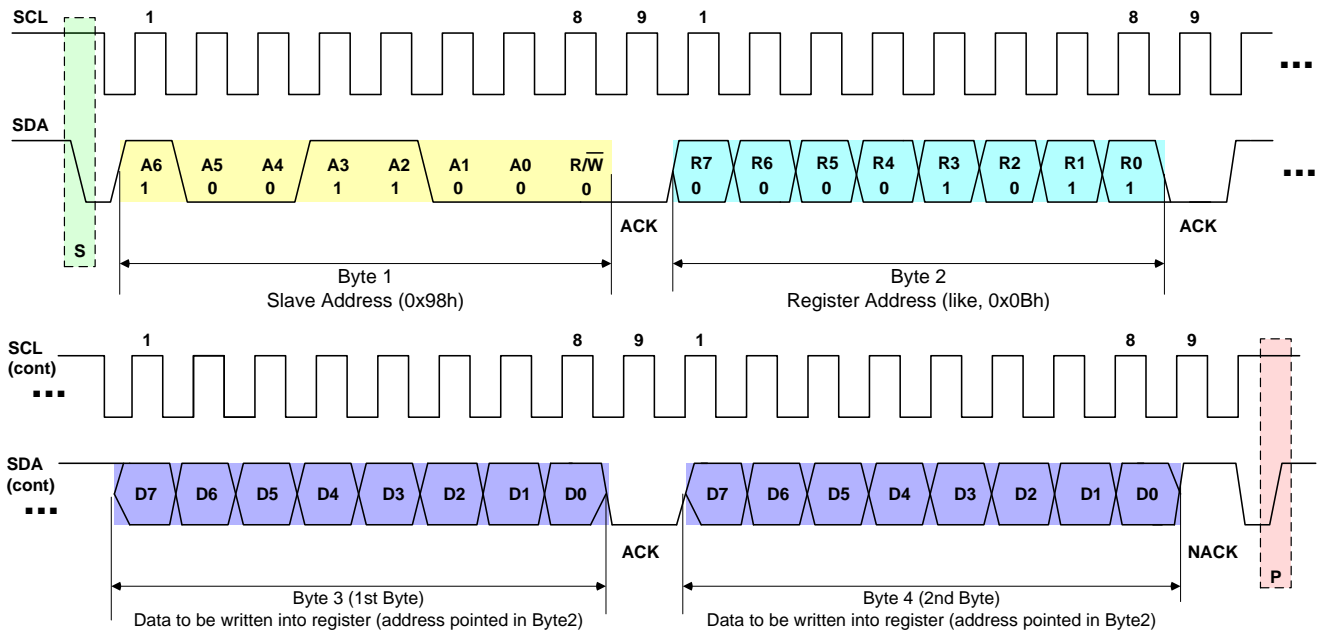

Figure-4. SMBus 2-byte Write Timing Diagram

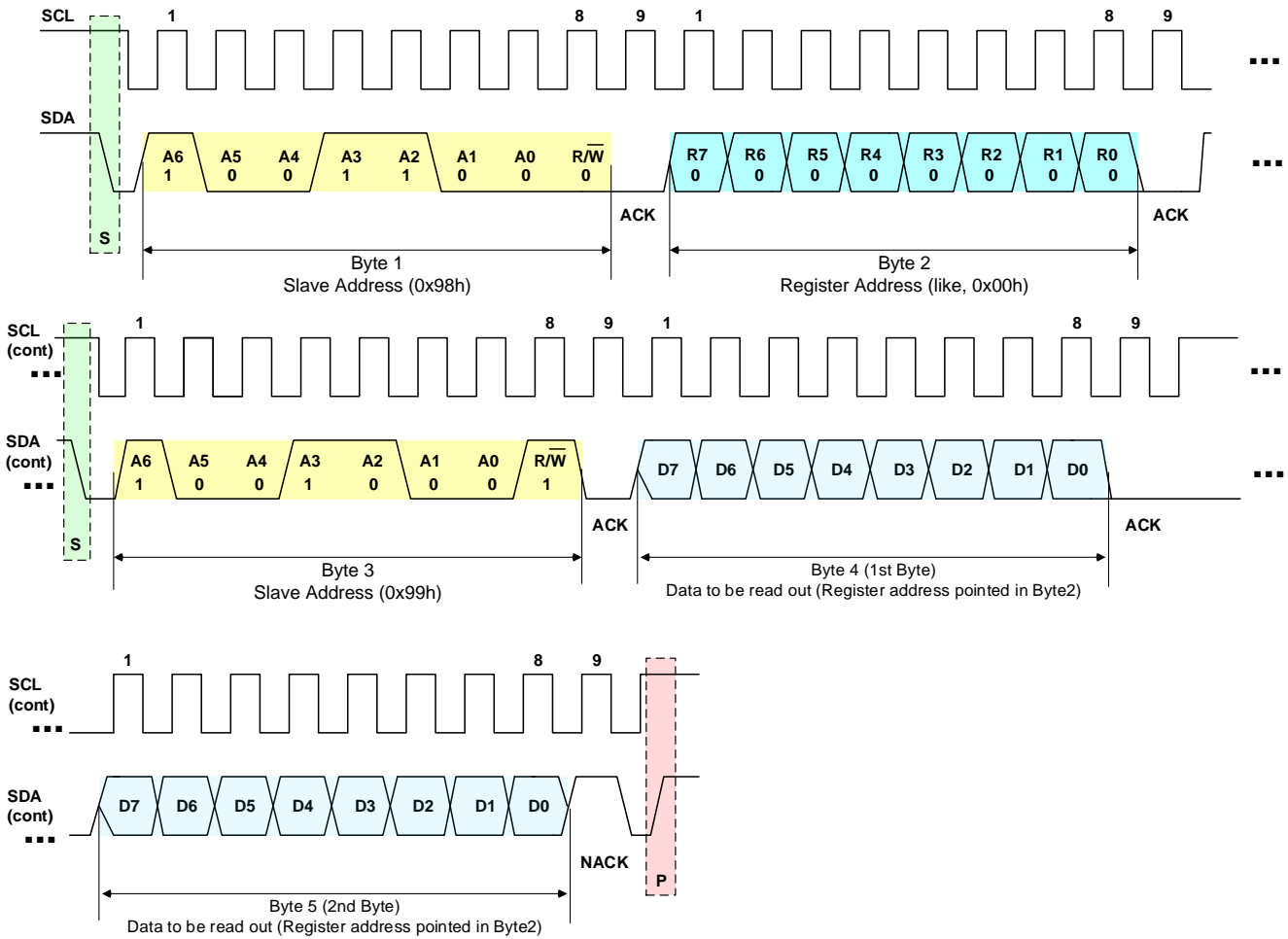

Figure-5. SMBus 2-byte Read Timing Diagram

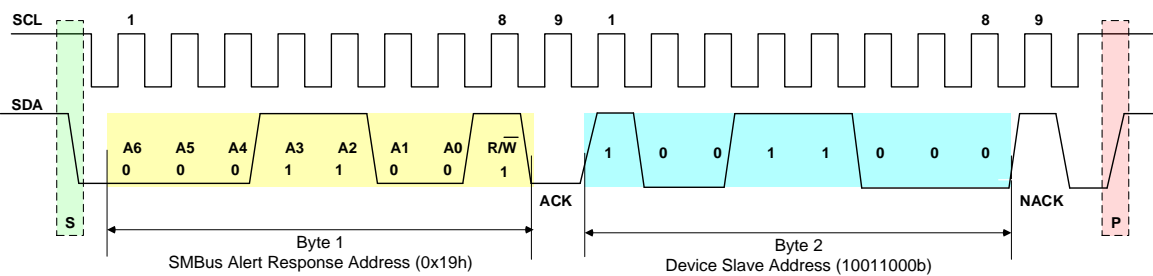

Figure-6. SMBus ALERT Response Diagram

Characteristics

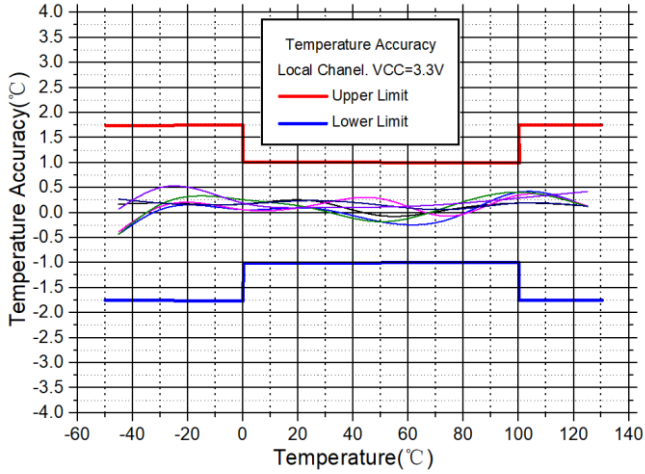

Figure-7. Temperature Accuracy vs. Temperature (Local)

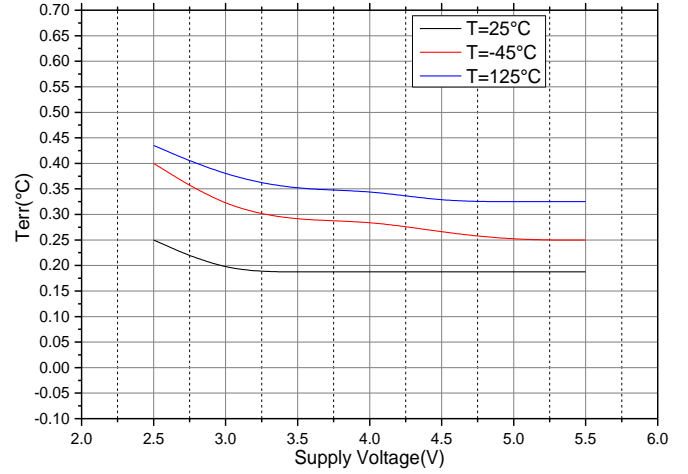

Figure-8. Temperature Accuracy vs. Supply Voltage (Remote)

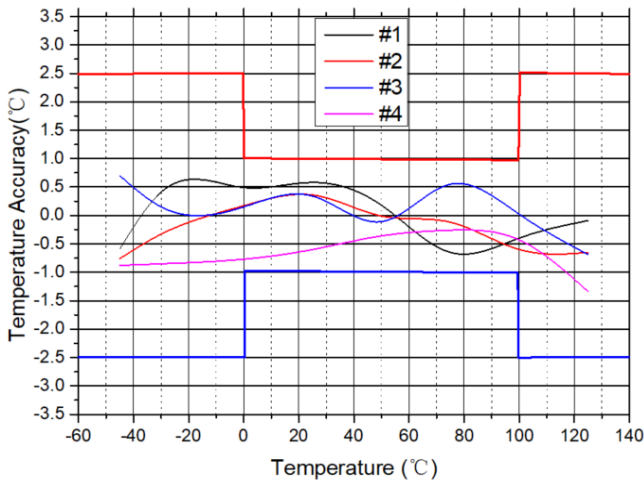

Figure-9. Temperature Accuracy vs. Temperature (Remote)

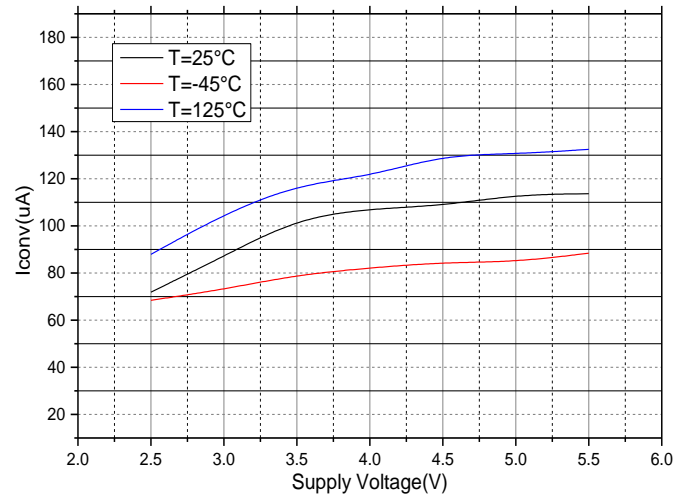

Figure-10. Conversion Current vs. Supply Voltage

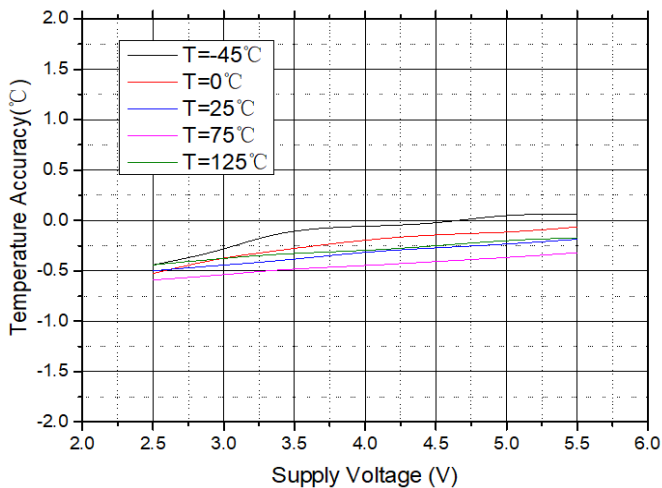

Figure-11. Temperature Accuracy vs. Supply Voltage (Local)

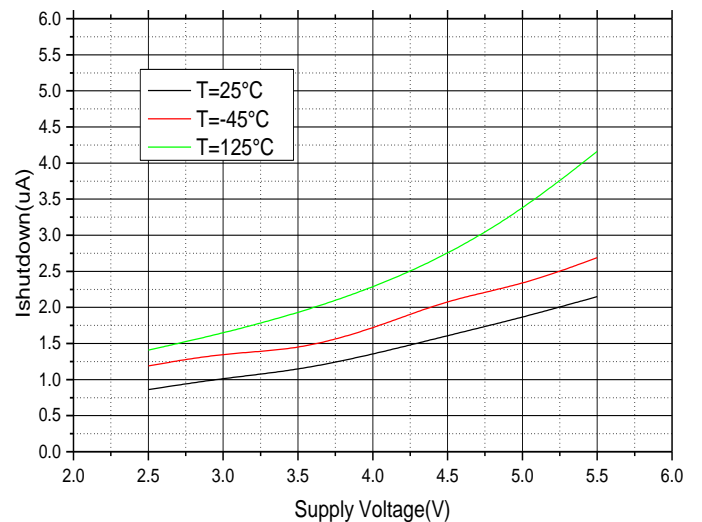

Figure-12. Shutdown Current vs. Supply Voltage

$\pm 1^{\circ}\text{C}$ Remote and Local Temperature Sensor
with Digital Interface
In a MSOP-8P and DFN3x3-8 Package

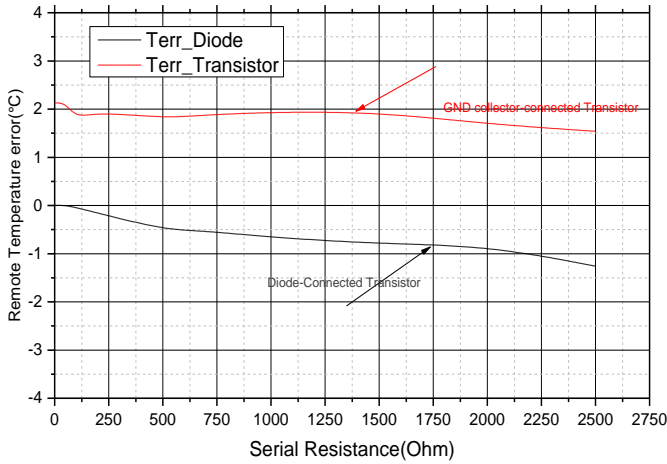

Figure-13. Temperature Accuracy vs. Serial Resistance

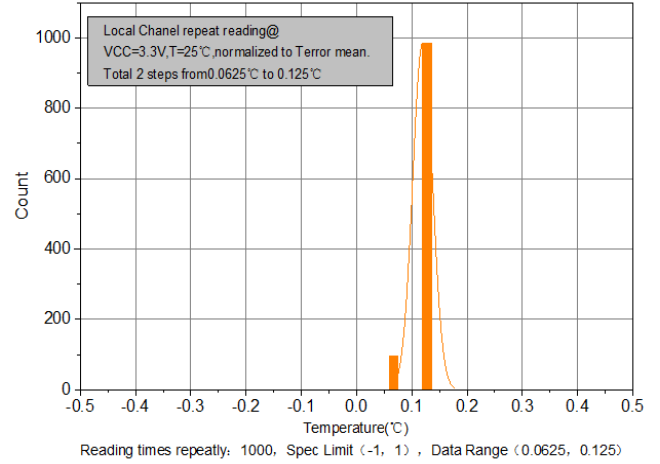

Figure-14. Local Channel Temperature Distribution

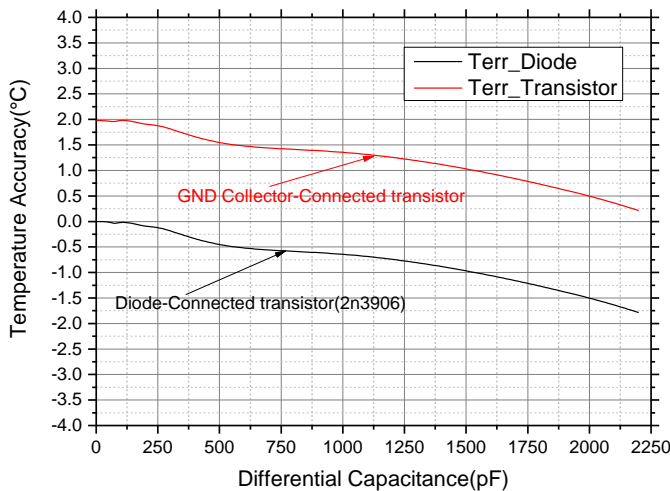

Figure-15. Temperature Accuracy vs. Differential Capacitance

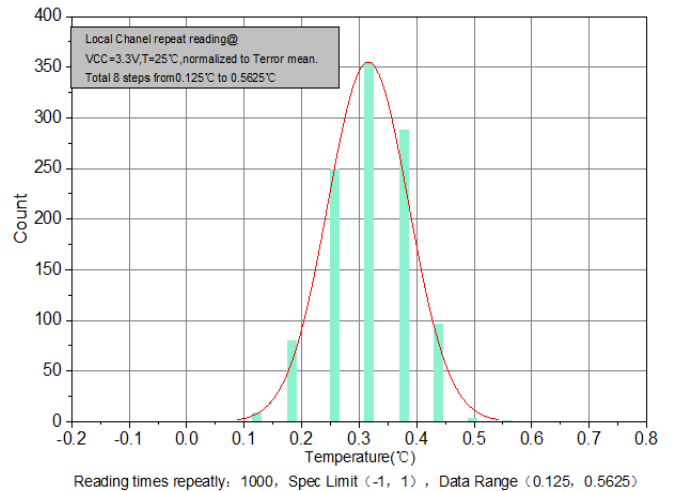

Figure-16. Remote Channel Temperature Distribution

±1°C Remote and Local Temperature Sensor with Digital Interface In a MSOP-8P and DFN3x3-8 Package

FUNCTION DESCRIPTION

Overview

The chip can sense 1 local channel and 1 remote channel temperature and convert them into digital data by a 12-bit ADC. Also the chip supports programmable high/low-limit temperature settings for all channels independently. If the measured temperature of any temperature channel drops below the low-limit or exceeds high-limit, ALERT pin will be asserted. If the measured temperature of any channel exceeds THERM limit (programmed by user), THERM pin will be asserted. For remote channels' high/low-limit temperature setup registers, there are 2 registers including MSB and LSB respectively. For THERM limit temperature setup registers, there is a hysteresis temperature setup register, which affects all local and remote channels.

Digital Output of Temperature Data

The temperature measurement data are in the local temperature and remote temperature registers (read only attribution). All local and remote channels' temperatures are stored in 12-bit binary format with the eight most significant bits (MSB) plus four least significant bits (LSB). And all other bits of low byte register are set to zero. These 2-Bytes temperature data can be read at the same time in one reading cycle (2-byte reading operation), 1st Byte is MSB followed by 2nd Byte, although register address is not adjacent. This can make sure both MSB and LSB byte data are from the same time of A-D conversion. For examples, local temperature data can be obtained from register address 0x00 in 2-byte reading operation.

If set bit2 (RANGE) of configuration 1 register as '0', the temperature data register of local and remote channels range is from 0x0000 to 0x7FF0, which means the expressed temperature range is from 0°C to 127.9375°C. If setting bit2 (RANGE) of configuration 1 as '1', the temperature range is extended from -64°C to 191°C. And the detail data format is shown as below tables.

Table 1. Sensor Temperature in 12-bit Digital Data (RANGE bit = 0, default)

Measured Temperature (°C)	Register Temperature (°C)	12-bit Digital Output (HEX)	8-bit Digital Output (BIN)(MSB)	4-bit Digital Output (BIN)(LSB)
+150.000	+127.9375	0x7FF0	0 1 1 1, 1 1 1 1	1 1 1 1, 0 0 0 0
+127.9375	+127.9375	0x7FF0	0 1 1 1, 1 1 1 1	1 1 1 1, 0 0 0 0
+100.500	+100.500	0x6480	0 1 1 0, 0 1 0 0	1 0 0 0, 0 0 0 0
+25.750	+25.750	0x19C0	0 0 0 1, 1 0 0 1	1 1 0 0, 0 0 0 0
0.000	0.000	0x0000	0 0 0 0, 0 0 0 0	0 0 0 0, 0 0 0 0
-25.750	0.000	0x0000	0 0 0 0, 0 0 0 0	0 0 0 0, 0 0 0 0
-40.000	0.000	0x0000	0 0 0 0, 0 0 0 0	0 0 0 0, 0 0 0 0

Table 2. Sensor Temperature in 12-bit Digital Data (RANGE bit = 1, default)

*Measured Temperature (°C)	Register Temperature (°C)	12-bit Digital Output (HEX)	8-bit Digital Output (BIN)(MSB)	4-bit Digital Output (BIN)(LSB)
+191.9375	+255.9375	0xFFFF	1 1 1 1, 1 1 1 1	1 1 1 1, 0 0 0 0
+150.000	+214.000	0xD600	1 1 0 1, 0 1 1 0	0 0 0 0, 0 0 0 0
+127.9375	+191.9375	0xBFF0	1 0 1 1, 1 1 1 1	1 1 1 1, 0 0 0 0
+100.500	+164.500	0xA480	1 0 1 0, 0 1 0 0	1 0 0 0, 0 0 0 0
+25.750	+89.750	0x59C0	0 1 0 1, 1 0 0 1	1 1 0 0, 0 0 0 0
0.000	+64.000	0x4000	0 1 0 0, 0 0 0 0	0 0 0 0, 0 0 0 0
-25.750	+38.250	0x2640	0 0 1 0, 0 1 1 0	0 1 0 0, 0 0 0 0
-40.000	+24.000	0x1800	0 0 0 1, 1 0 0 0	0 0 0 0, 0 0 0 0
-64.000	0.000	0x0000	0 0 0 0, 0 0 0 0	0 0 0 0, 0 0 0 0

* Measured Temperature (°C) = Register Temperature (°C) - 64(°C)

±1°C Remote and Local Temperature Sensor with Digital Interface In a MSOP-8P and DFN3x3-8 Package

Higher than 128°C

When measured temperature of local and/or remote channels is equal or higher than 128°C, set bit2 (RANGE) of configuration 1 register as '1' will extend the temperature range from 0°C to 127°C into -64°C to 191°C. The difference is bit7 of temperature MSB data is used as 128°C in extended format. Once this bit is set as '1', user has to note that:

- 1). the actual measured temperature is calculated by register temperature minus 64°C;
- 2). It has to keep high/low-limit alert temperature registers as the same format as temperature data manually;
- 3). although the expression temperature is -64°C to 191°C in this mode, for this sensor chip, it is better to keep within -40°C to 125°C, for external thermal diodes or transistors, it is better to keep within -55°C to 150°C.

Table 3. Temperature Range Setup

Bit2 (RANGE)	Temperature Range (°C)	Register Range(HEX, MSB only)
0 (default)	0 to 127	0x00 to 0x7F
1	-64 to 191	0x00 to 0xFF

Operating Mode, Active and Standby

The chip has 2 operation modes:

- 1). Active (by setting STB bit, bit6 of Configuration 1 Register as '0'): In this mode, the ADC is doing conversion on all temperature sensor channels at the programmed conversion rate. The temperature data is updated and limitation is checked at the end of every conversion cycle. In this mode, writing to the one-shot register (Add = 0x0F), the chip has no response.
- 2). Standby (by setting STB bit, bit6 of Configuration 1 Register as '1'): In this mode, most circuit blocks are powered down to reduce operation current. The SMBus is active and the chip will return requested data. Writing any data to the one-shot register (0x0F) will do one-time temperature conversion for all enable channels (setup by Configuration Register2 [5:3] bits). Once all enabled sensor channels are updated, the chip will return to standby mode again until STB bit is set as '0'.

±1°C Remote and Local Temperature Sensor with Digital Interface In a MSOP-8P and DFN3x3-8 Package

Register Map (All registers are shown as below table.) ⁽¹⁾

Table 4. PJ85431 Register Map

Address	Register Name	Attribution	Default Data	BIT								
				7	6	5	4	3	2	1	0	
0x00	LT_MSB	R/O	0x00	LT11	LT10	LT9	LT8	LT7	LT6	LT5	LT4	
0x01	RT_MSB	R/O	0x00	RT1	RT0	RT9	RT8	RT7	RT6	RT5	RT4	
0x02	STATUS	R/O	0x80	BUSY	LHIGH	LLOW	RHIGH	RLOW	OPEN	RTHRM	LTHRM	
0x03	Configuration 1	R/W	0x00	ALTMASK	STB	AL/TH	0	0	RANGE	0	0	
0x04	Conv_Rate	R/W	0x07	0	0	0	0	Conv_Rate[3:0]				
0x05	LT_HAT_MSB	R/W	0x55	LT_HAT[11:4]								
0x06	LT_LAT_MSB	R/W	0x00	LT_LAT[11:4]								
0x07	RT_HAT_MSB	R/W	0x55	RT_HAT[11:4]								
0x08	RT_LAT_MSB	R/W	0x00	RT_LAT[11:4]								
0x09	Configuration 1	R/W	0x00	ALTMASK	STB	AL/TH	0	0	RANGE	0	0	
0x0A	Conv_Rate	R/W	0x07	0	0	0	0	Conv_Rate[3:0]				
0x0B	LT_HAT_MSB	R/W	0x55	LT_HAT[11:4]								
0x0C	LT_LAT_MSB	R/W	0x00	LT_LAT[11:4]								
0x0D	RT_HAT_MSB	R/W	0x55	RT_HAT[11:4]								
0x0E	RT_LAT_MSB	R/W	0x00	RT_LAT[11:4]								
0x0F	One_Shot_Con	W/O	N/A	It is a write only register; write any data into this register will trig one time temperature measurement for all enabled channels. It is available only in shutdown mode.								
0x10	RT_LSB	R/O	0x00	RT3	RT2	RT1	RT0	RSV				
0x13	RT_HAT_LSB	R/W	0x00	RT_HAT[3:0]				RSV				
0x14	RT_LAT_LSB	R/W	0x00	RT_LAT[3:0]				RSV				
0x15	LT_LSB	R/O	0x00	LT3	LT2	LT1	LT0	0	0	0	0	
0x16	LT_HAT_LSB	R/W	0x00	LT_HAT[3:0]				0	0	0	0	
0x17	LT_LAT_LSB	R/W	0x00	LT_LAT[3:0]				0	0	0	0	
0x18	n-Factor Correction	R/W	0x00	NC[7:0]								
0x19	RT_THERM_LIMIT	R/W	0x55	RT_THERM[7:0]								
0x1A	Configuration 2	R/W	0x1C	0	0	0	REN	LEN	SRCEN	0	0	
0x1F	CH_Mask	R/W	0x00	RSV							RMSK	LMSK
0x20	LT_THERM_LIMIT	R/W	0x55	LT_THERM[7:0]								
0x21	THERM_HYS	R/W	0x0A	THERM_HYS[7:0]								
0x22	ALT_THM_CON	R/W	0x70	0	THM_CON[2:0]			ALT_CON[2:0]			0	
0x25	beta_compensation	R/W	0x0F	RSV				BC3	BC2	BC1	BC0	
0xFC	Soft_Reset	W/O	0x00	x	x	x	x	x	x	x	x	
0xFD	Device_ID	R/O	0x31	0x31								
0xFE	Manufacturer_ID	R/O	0x59	0x59								

(1) R/W -- Readable/Writable; R/O -- read only; W/O -- write only; X -- do not care whatever '0' or '1'. RSV -- Reserved; N/A -- Not applicable.

**±1°C Remote and Local Temperature Sensor
with Digital Interface
In a MSOP-8P and DFN3x3-8 Package**

Table 5. PJ85431P Register Map

Address	Register Name	Attribution	Default Data	BIT							
				7	6	5	4	3	2	1	0
0x00	LT_MSB	R/O	0x00	LT11	LT10	LT9	LT8	LT7	LT6	LT5	LT4
0x01	RT_MSB	R/O	0x00	RT1	RT0	RT9	RT8	RT7	RT6	RT5	RT4
0x02	STATUS	R/O	0x80	BUSY	LHIGH	LLOW	RHIGH	RLOW	OPEN	RTHRM	LTHRM
0x03	Configuration 1	R/W	0x00	ALTMASK	STB	AL/TH	0	0	RANGE	0	0
0x04	Conv_Rate	R/W	0x07	0	0	0	0	Conv_Rate[3:0]			
0x05	LT_HAT_MSB	R/W	0x55	LT_HAT[11:4]							
0x06	LT_LAT_MSB	R/W	0x00	LT_LAT[11:4]							
0x07	RT_HAT_MSB	R/W	0x55	RT_HAT[11:4]							
0x08	RT_LAT_MSB	R/W	0x00	RT_LAT[11:4]							
0x09	Configuration 1	R/W	0x00	ALTMASK	STB	AL/TH	0	0	RANGE	0	0
0x0A	Conv_Rate	R/W	0x07	0	0	0	0	Conv_Rate[3:0]			
0x0B	LT_HAT_MSB	R/W	0x55	LT_HAT[11:4]							
0x0C	LT_LAT_MSB	R/W	0x00	LT_LAT[11:4]							
0x0D	RT_HAT_MSB	R/W	0x55	RT_HAT[11:4]							
0x0E	RT_LAT_MSB	R/W	0x00	RT_LAT[11:4]							
0x0F	One_Shot_Con	W/O	N/A	It is a write only register; write any data into this register will trig one time temperature measurement for all enabled channels. It is available only in shutdown mode.							
0x10	RT_LSB	R/O	0x00	RT3	RT2	RT1	RT0	RSV			
0x13	RT_HAT_LSB	R/W	0x00	RT_HAT[3:0]				RSV			
0x14	RT_LAT_LSB	R/W	0x00	RT_LAT[3:0]				RSV			
0x19	RT_THERM_LIMIT	R/W	0x55	RT_THERM[7:0]							
0x1F	CH_Mask	R/W	0x00	RSV						RMSK	LMSK
0x20	LT_THERM_LIMIT	R/W	0x55	LT_THERM[7:0]							
0x21	THERM_HYS	R/W	0x0A	THERM_HYS[7:0]							
0x22	ALT_THM_CON	R/W	0x70	0	THM_CON[2:0]			ALT_CON[2:0]			0
0x25	beta_compesation	R/W	0x0F	RSV				BC3	BC2	BC1	BC0
0x27	n-Factor Correction	R/W	0x00	NC[7:0]							
0x29	LT_LSB	R/O	0x00	LT3	LT2	LT1	LT0	0	0	0	0
0xFC	Soft_Reset	W/O	0x00	x	x	x	x	x	x	x	x
0xFD	Device_ID	R/O	0x12	0x12							
0xFE	Manufacturer_ID	R/O	0x59	0x59							

(1) R/W -- Readable/Writable; R/O -- read only; W/O -- write only; X -- do not care whatever '0' or '1'. RSV -- Reserved; N/A -- Not applicable.

±1°C Remote and Local Temperature Sensor with Digital Interface In a MSOP-8P and DFN3x3-8 Package

Register Description

Temperature Data, including 1 Local Channel and 1 Remote Channel

- Register Address: 0x00, 0x01, 0x10, 0x15 (PJ85431) or 0x29(PJ85431P)
- Register Attribution: Read only
- Default Data: 0x00in Standby mode after POR

For each channel, temperature in Celsius degree is formed by 2-bytes data, MSB plus LSB, which expressed in 12-bit binary format. The definition of each bit is shown as below table. The resolution is 0.0625°C, and the expressed range is from 0°C to +127.9375°C when range bit is '0' or -64°C to +191.9375°C when range bit is '1'. However the sensor chip worked temperature range only from -40°C to 125°C, the range can be extended -50°C to 150°C or above for remote channels. The last 4 bits of LSB byte are always 0 after reading.

Channel	MSB Data (Address)	LSB Data (Address)
Local	0x00	0x15 (0x29 for PJ85431P)
Remote	0x01	0x10

	MSB								LSB							
BIT	7	6	5	4	3	2	1	0	7	6	5	4	3	2	1	0
Number	T11	2 ⁶	2 ⁵	2 ⁴	2 ³	2 ²	2 ¹	2 ⁰	2 ⁻¹	2 ⁻²	2 ⁻³	2 ⁻⁴	0	0	0	0
Degree(°C)	0/128 ⁽¹⁾	64	32	16	8	4	2	1	0.5	0.25	0.125	0.0625	0	0	0	0
Default	0	0	0	0	0	0	0	0	0	0	0	0	0	0	0	0

(1) RANGE bit = 0, bit7 is used as 0 always; RANGE bit = 1, bit7 is used as 128°C;

STATUS Register, to indicate the chip ALERT, THERM and remote diodes open Status

- Register Address: 0x02
- Register Attribution: Read only
- Default Data: 0x80 for 0x02 register

BIT	Name	Description
7	BUSY	1 – Means ADC is busy for temperature converting.
6	LHIGH	AL/TH ⁽²⁾ = 0, pin6 is used as ALERT feature 1 – Means temperature of local channel is higher than that of programmed value in local high-limit register; this bit will be kept as '1' even temperature of local channel drops below local-high-limit value. This bit is reset as '0' only after reading status register or resetting the chip. ALT_TM = 1, pin6 is used as 2 nd THERM feature 1 – Means temperature of local channel is higher than that of programmed value in local high-limit register; and this pin will be reset as '0' once temperature of local channel drops below temperature minus hysteresis.
5	LLow	1 – Means temperature of local channel is lower than that of programmed value in local low-limit register; this bit will be kept as '1' even temperature of local channels exceeds local-low-limit value. This bit is reset as '0' only after reading status register or resetting the chip.
4	RHIGH	ALT_TM ⁽²⁾ = 0, pin6 is used as ALERT feature 1 – Means temperature of remote channel is higher than that of programmed value in remote high-limit register; this bit will be kept as '1' even temperature of remote channel drops below remote-high-limit value. This bit is reset as '0' only after reading status register or resetting the chip. ALT_TM = 1, pin6 is used as 2 nd THERM feature 1 – Means temperature of remote channel is higher than that of programmed value in remote high-limit register; and this pin will be reset as '0' once temperature of remote channel drops below temperature minus hysteresis.

±1°C Remote and Local Temperature Sensor with Digital Interface In a MSOP-8P and DFN3x3-8 Package

BIT	Name	Description
3	RLOW	Whatever AL/TH ⁽¹⁾ bit = 0 or 1 1 – Means temperature of remote channel is lower than that of programmed value in remote low-limit register; this bit will be kept as '1' even temperature of remote channels exceeds remote low-limit value. This bit is reset as '0' only after reading status register or resetting the chip.
2	OPEN	1 – Means remote diode is open/disconnected. This bit will be kept as '1' even remote diode is connected correctly. This bit is reset as '0' only after reading status register or resetting the chip.
1	R THERM	1 – Means temperature of remote channel exceeds that of setup value in RT_THERM_LIMIT register (Address 0x19). This bit will be updated only after temperature conversion for remote channel. This bit is '0' if temperature of remote channel drops below setup value in RT_THERM_LIMIT register minus hysteresis temperature (Address 0x21).
0	L THERM	1 – Means temperature of local channel exceeds that of setup value in LT_THERM_LIMIT register (address 0x20). This bit will be updated only after temperature conversion for local channel. This bit is '0' if temperature of local channel drops below setup value in LT_THERM_LIMIT register minus hysteresis temperature (Address 0x21).

(1) AL/TH bit is bit5 of configuration 1 register (Address, 0x03);

Configuration Registers, including Configuration 1 and 2

- Register Address: 0x03 (Read/Write) and 0x09 (Read/Write) for Configuration 1, 0x1A for Configuration 2
- Register Attribution: As above
- Default Data: 0x00 for Configuration 1, 0x1C for Configuration 2

- Configuration 1

BIT	7	6	5	4	3	2	1	0
Name	ALTMASK	STB	AL/TH	0	0	RANGE	0	0
Default	0	0	0	0	0	0	0	0

BIT	Name	Description
7	ALTMASK	0 – Disable to mask all ALERT interrupt function; 1 – Enable to mask all ALERT interrupt function; Note, if ALT_TM = 1, this bit has no any effect with '0' or '1'.
6	STB	0 – The chip is active and working normally; 1 – The chip is in standby mode.
5	AL/TH	0 – Configure PIN6 as ALERT function; 1 – Configure PIN6 as THERM2 function;
4:3	0	No definition, always '0' after reading.
2	RANGE	0 – Temperature expression range is 0°C to 127°C; 1 – Temperature expression range is -64°C to 191°C.
1:0	0	No definition, always '0' after reading.

- Configuration 2

BIT	7	6	5	4	3	2	1	0
Name	0	0	0	REN	LEN	SRCEN	0	0
Default	0	0	0	1	1	1	0	0

**±1°C Remote and Local Temperature Sensor
with Digital Interface
In a MSOP-8P and DFN3x3-8 Package**

BIT	Name	Description
7	ALTMSK	0 – Disable to mask all ALERT interrupt function; 1 – Enable to mask all ALERT interrupt function; Note, if ALT_TM = 1, this bit has no any effect with '0' or '1'.
6	STB	0 – The chip is active and working normally; 1 – The chip is in standby mode.
5	AL/TH	0 – Configure PIN6 as ALERT function; 1 – Configure PIN6 as THERM2 function;
4:3	0	No definition, always '0' after reading.
2	RANGE	0 – Temperature expression range is 0°C to 127°C; 1 – Temperature expression range is -64°C to 191°C.
1:0	0	No definition, always '0' after reading.

Conv_Rate, Conversion Rate Setup Register of ADC

- Register Address: 0x04(Read/Write) and 0x0A(Read/Write)
- Register Attribution: As above
- Default Data: 0x07

BIT	7	6	5	4	3	2	1	0
Name	0	0	0	0	Conv_Rate [3:0]			
Default	0	0	0	0	0	1	1	1

BIT	NAME	Description
7:4	0	No definition, always '0' after reading.
3:0	Conv_Rate [3:0]	Conversion Rate Selection,
		Code Cons/s Conversion Time (s)
		0000 0.0625 16
		0001 0.125 8
		0010 0.25 4
		0011 0.5 2
		0100 1.0 1
		0101 2.0 0.5
		0110 4.0 0.25
		0111 8.0 0.125(default)
		1000 8.0 0.125
1xxx 8.0 0.125		

ALT_THM_CON, ALERT and THERM Consecutive Setup

- Register Address: 0x22
- Register Attribution: Read/Write
- Default Data: 0x07

This register is used to setup the number of consecutive times to trigger ALERT or THERM conditions. The default is 0x70, which means 1 time trigger condition happens will cause ALERT pin to be active and 4 times trigger condition happens will cause THERM pin to be active.

±1°C Remote and Local Temperature Sensor with Digital Interface In a MSOP-8P and DFN3x3-8 Package

BIT	7	6	5	4	3	2	1	0
Name	0	THM_CON2	THM_CON1	THM_CON0	ALT_CON2	ALT_CON1	ALT_CON0	0
Default	0	0	0	0	0	0	0	0

BIT	NAME	Description
7	EN ⁽¹⁾	0 – Timeout Disable 1 – Timeout Enable
6:4	TM_COM[2:0]	To setup the number of consecutive times to trig THERM condition, 000 – 1 001 – 2 011 – 3 111 – 4
3:1	ALT_CON[2:0]	To setup the number of consecutive times to trig ALERT condition, 000 – 1 001 – 2 011 – 3 111 – 4
0	0	No definition, always '0' after reading.

(1) This bit is only valid for PJ85431P. For PJ85431, SMBus timeout is always enable although this bit always '0' after reading.

One_Shot_Con, used for One Time Conversion

- Register Address: 0x0F
- Register Attribution: Write only

This register is used to perform one shot temperature measurement. When the chip is in standby mode, writing any data (0x00 to 0xFF) into this register will activate ADC to update all enabled channels measurement. In active mode, writing data into this register has no any effect to the chip. The attribution of this register is write-only. Data written to this register is not stored and the data read from this register is always 0x00.

ALERT LIMIT, including Local and Remote Channels high/low-limit

For each channel, there are high-limit and low-limit threshold temperature. And there are 2-byte called MSB and LSB to form one threshold temperature. So totally there are 8 bytes to setup in different register address. The chip supports 2-byte reading operation, which can obtain high/low threshold temperature in one reading cycle. It is similar as temperature reading. Also the chip supports 2-byte writing operation.

For examples, to setup local channel high-limit threshold temperature as 100.5°C, just writing 2-bytes data 0x64, 0x80 into register address, 0x0B in 2-byte writing operation.



For examples, to read remote channel low-limit threshold temperature, just reading 2-bytes data from register address, 0x08 in 2-byte reading operation.

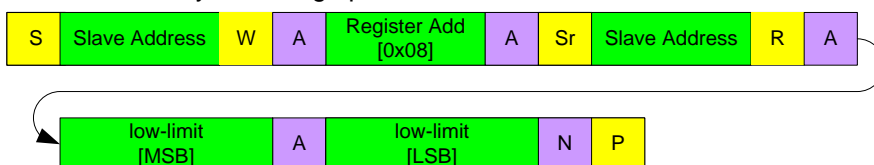

±1°C Remote and Local Temperature Sensor with Digital Interface In a MSOP-8P and DFN3x3-8 Package

- All channels high/low-limit threshold registers are listed as below table.

Channel	High-limit Register Address		Low-limit Register Address	
	MSB	LSB	MSB	LSB
Local	0x05: R/W; 0x0B: R/W Default: 0x55	0x16: R/W Default: 0x00	0x06: R/W; 0x0C: R/W Default: 0x00	0x17: R/W Default: 0x00
	Default: 85°C (RANGE = 0), 21°C (RANGE = 1)		Default: 0°C (RANGE = 0), -64°C (RANGE = 1)	
Remote	0x07: R/W; 0x0D: R/W Default: 0x55	0x13: R/W Default: 0x00	0x08: R/W; 0x0E: R/W Default: 0x00	0x14: R/W Default: 0x00
	Default: 85°C (RANGE = 0), 21°C (RANGE = 1)		Default: 0°C (RANGE = 0), -64°C (RANGE = 1)	

It is important to note that, the high/low-limit format for each channel is always the same as that of temperature obtained from register 0x00 and 0x01. For example, in default the high-limit register of local channel is 0x55, which stands for 85°C. However if user changes RANGE bit as '1', this register data will not be changed automatically. The register data still is 0x55, which stands for 85°C – 64°C = 21°C.

If pin6 of the chip is used as 2nd THERM pin, then the values stored in high-limit registers each channel are taken as relative threshold temperature for THERM2.

THERM LIMIT, including Local and Remote Channels THERM Limit

There are 3 registers used to setup THERM limit value for local (Address 0x20) and remote (Address 0x19) channels with 1-byte THERM hysteresis (Address 0x21). There is only 1-byte for each THERM limit register, with 1°C resolution. Also the format is always the same as that of temperature. For example, the default THERM-limit data for local channel is 0x55, which stands for 85°C if RANGE bit is '0', and stands for 21°C if RANGE bit is '1'.

Channel	THERM-limit Register Address	THERM Hysteresis Register Address
Local	0x20: R/W, Default 0x55 85°C (RANGE = 0), 21°C (RANGE = 1)	0x21: R/W, Default 0x0A 10°C (RANGE = 0 or RANGE = 1)
Remote	0x19: R/W, Default 0x55 85°C (RANGE = 0), 21°C (RANGE = 1)	0x21: R/W, Default 0x0A 10°C (RANGE = 0 or RANGE = 1)

THERM_HYS, THERM Limit Hysteresis Temperature

- Register Address: 0x21
- Register Attribution: Read/Write
- Default Data: 0x0A, stands for 10°C whatever RANGE bit is 0 or 1, the range is 0°C to 255°C with 1°C resolution.

It is note that the setup temperature in this register should be less than that of high-limit or THERM-limit of any channel (local or remote), or the logic will conflict and THERM trigger will not happen.

Temperature (°C)	Register in HEX	Register in BIN
+255	0xFF	1111, 1111
+200	0xC8	1100, 1000
+150	0x96	1001, 0110
+127	0x7F	0111, 1111
+10	0x0A	0000, 1010
+1	0x01	0000, 0001
0	0x00	0000, 0000

Beta Compensation, for Remote Channel

- Register Address: 0x25 for remote channel
- Register Attribution: Read/Write
- Default Data: 0x08

This register is used to compensate temperature error caused by lower beta or beta variation of PNP transistor especially parasitic substrate transistor inside CPU, GPU, FPGA or SoC chip as remote diode. Set bit3 as '1' will select automatically beta range; Set bit3 as '0' will select manually beta range.

Channel	Address	Default Data, Bits
Remote	0x25	0x08, Bit[3:0]

Item	BC [3:0]	Description
1	0000	Manually setup beta range 1, $0.08 < \beta < 0.50$
2	0001	Manually setup beta range 2, $0.15 < \beta < 1.0$
3	0010	Manually setup beta range 3, $0.20 < \beta < 2.0$
4	0011	Manually setup beta range 4, $0.30 < \beta < 15$
5	0100	Manually setup beta range 5, $0.60 < \beta < 50$
6	0101	Manually setup beta range 6, $1.2 < \beta < 100$
7	0110	Manually setup beta range 7, $2.5 < \beta < 150$
8	0111	Disable beta compensation
9	1000	Automatically setup beta range 1, $0.08 < \beta < 0.20$
10	1001	Automatically setup beta range 2, $0.15 < \beta < 0.30$
11	1010	Automatically setup beta range 3, $0.20 < \beta < 0.40$
12	1011	Automatically setup beta range 4, $0.30 < \beta < 0.70$
13	1100	Automatically setup beta range 5, $0.60 < \beta < 1.50$
14	1101	Automatically setup beta range 6, $1.30 < \beta < 8.0$
15	1110	Automatically setup beta range 7, $6.00 < \beta < 30$
16	1111	Automatically setup beta range 8, $25.0 < \beta < +\infty$

N-Factor_Correction, for Remote Channel

- Register Address: 0x18(PJ85431) or 0x27(PJ85431P)
- Register Attribution: Read/Write
- Default Data: 0x00

This register is used to correct temperature error caused by non-ideality factor from remote diodes by setting proper n value. User can change the slope of remote channels over full temperature range by selecting a different n-factor value. This feature can be used to fit different remote PN junction. The register default value is 0x00 after POR, and n is 1.008.

±1°C Remote and Local Temperature Sensor with Digital Interface In a MSOP-8P and DFN3x3-8 Package

Hex (Register)	N _{DEC}	Binary	n _{NEW}
0x7F	127	0111 1111	1.7479769
0x0A	10	0000 1010	1.0427586
0x08	8	0000 1000	1.0356164
0x06	6	0000 0110	1.0285714
0x04	4	0000 0100	1.0216216
0x02	2	0000 0010	1.0147651
0x01	1	0000 0001	1.0113712
0x00	0	0000 0000	1.008 (default)
0xFF	-1	1111 1111	1.0046512
0xFE	-2	1111 1110	1.0013245
0xFC	-4	1111 1100	0.9947368
0xFA	-6	1111 1010	0.9882353
0xF8	-8	1111 1000	0.9818182
0xF6	-10	1111 0110	0.9754839
0x80	-128	1000 0000	0.7065421

In above table, the column 'Hex' is the data to be written into N-Factor_Correction register, the related n-Factor is shown in column 'n_{NEW}'. For example, if writing data 0x0A into Register address 0x18, then n will be changed into 1.0427586 from default 1.008. The relationship between register data and n_{NEW} can be expressed by below equation.

$$n_{NEW} = \frac{1.008 \times 300}{300 - N_{DEC}}$$

- n_{NEW}, final n value after writing new data into register.
- N_{DEC}, Register data expressed in Decimal, which is in two's complement format.

CH_Mask, Mask Setup individually for each channel

- Register Address: 0x1F
- Register Attribution: Read/Write
- Default Data: 0x00 after POR

BIT	Name	Description
7:2	RSV	Reserved bits, always 0 after reading.
1	RMSK	0 – Enable remote channel ALERT function; 1 – Mask remote channel ALERT function; Note, if bit7 (ALTMASK) of configuration 1 is 1, this bit has no any effect to chip whatever '0' or '1'.
0	LMSK	0 – Enable local channel ALERT interrupt function; 1 – Mask local channel ALERT interrupt function; Note, if bit7 (ALTMASK) of configuration 1 is 1, this bit has no any effect to chip whatever '0' or '1'.

±1°C Remote and Local Temperature Sensor with Digital Interface In a MSOP-8P and DFN3x3-8 Package

Device_ID

- Register Address: 0xFD
- Register Attribution: Read only
- Default Data: PJ85431 is 0x31 , PJ85431P is 0x12

Manufacturer_ID

- Register Address: 0xFE
- Register Attribution: Read only
- Default Data: 0x59

SMBus Digital Interface

Slave Address

For PJ85431P, the SMBus or I²C slave address of this device can be setup by user via connecting different pull-up resistor for THERM pin (pin4). It is important to note that the voltage connecting the pull-up resistor, should be same with V_{CC} of the chip. Also the chip supports different slave address after production, distinguished by different suffix A to H. Please contact Metawells sales if user wants other address device.

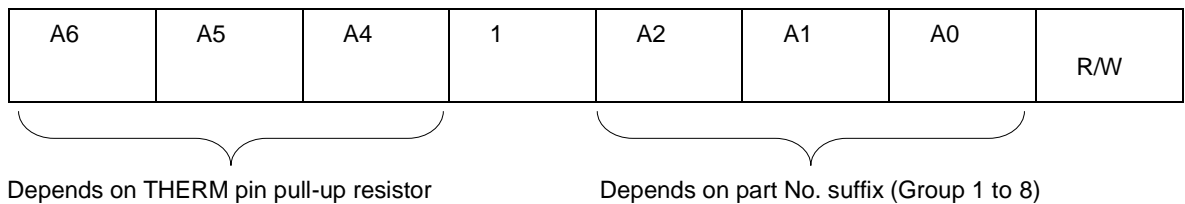

For examples, THERM pin pull-up resistor is 4.7k, Part No. is PJ85431P, and the slave address is 0xF8/0xF9 in Hex with write / read operation. The specific I²C address is shown in the table below:

Item	Part No.	Group	THERM PIN Pull-up Resistor	Slave Address (W/R)
1	PJ85431P	Group 1	4.7 k (±5%)	0xF8/0xF9
2	PJ85431P	Group 1	6.8 k (±5%)	0xB8/0xB9
3	PJ85431P	Group 1	10 k (±5%)	0x98/0x99
4	PJ85431P	Group 1	15 k (±5%)	0xD8/0xD9
5	PJ85431P	Group 1	22 k (±5%)	0x38/0x39
6	PJ85431P	Group 1	33 k (±5%)	0x78/0x79
7	PJ85431PA	Group 2	4.7 k (±5%)	0xF0/0xF1
8	PJ85431PA	Group 2	6.8 k (±5%)	0xB0/0xB1
9	PJ85431PA	Group 2	10 k (±5%)	0x90/0x91
10	PJ85431PA	Group 2	15 k (±5%)	0xD0/0xD1
11	PJ85431PA	Group 2	22 k (±5%)	0x30/0x31
12	PJ85431PA	Group 2	33 k (±5%)	0x70/0x71
13	PJ85431PB	Group 3	4.7 k (±5%)	0xF2/0xF3
14	PJ85431PB	Group 3	6.8 k (±5%)	0xB2/0xB3
15	PJ85431PB	Group 3	10 k (±5%)	0x92/0x93
16	PJ85431PB	Group 3	15 k (±5%)	0xD2/0xD3
17	PJ85431PB	Group 3	22 k (±5%)	0x32/0x33
18	PJ85431PB	Group 3	33 k (±5%)	0x72/0x73
19	PJ85431PC	Group 4	4.7 k (±5%)	0xF4/0xF5

**±1°C Remote and Local Temperature Sensor
with Digital Interface
In a MSOP-8P and DFN3x3-8 Package**

Item	Part No.	Group	THERM PIN Pull-up Resistor	Slave Address (W/R)
20	PJ85431PC	Group 4	6.8 k (±5%)	0xB4/0xB5
21	PJ85431PC	Group 4	10 k (±5%)	0x94/0x95
22	PJ85431PC	Group 4	15 k (±5%)	0xD4/0xD5
23	PJ85431PC	Group 4	22 k (±5%)	0x34/0x35
24	PJ85431PC	Group 4	33 k (±5%)	0x74/0x75
25	PJ85431PD	Group 5	4.7 k (±5%)	0xF6/0xF7
26	PJ85431PD	Group 5	6.8 k (±5%)	0xB6/0xB7
27	PJ85431PD	Group 5	10 k (±5%)	0x96/0x97
28	PJ85431PD	Group 5	15 k (±5%)	0xD6/0xD7
29	PJ85431PD	Group 5	22 k (±5%)	0x36/0x37
30	PJ85431PD	Group 5	33 k (±5%)	0x76/0x77
31	PJ85431PE	Group 6	4.7 k (±5%)	0xFA/0xFB
32	PJ85431PE	Group 6	6.8 k (±5%)	0xBA/0xBB
33	PJ85431PE	Group 6	10 k (±5%)	0x9A/0x9B
34	PJ85431PE	Group 6	15 k (±5%)	0xDA/0xDB
35	PJ85431PE	Group 6	22 k (±5%)	0x3A/0x3B
36	PJ85431PE	Group 6	33 k (±5%)	0x7A/0x7B
37	PJ85431PF	Group 7	4.7 k (±5%)	0xFC/0xFD
38	PJ85431PF	Group 7	6.8 k (±5%)	0xBC/0xBD
39	PJ85431PF	Group 7	10 k (±5%)	0x9C/0x9D
40	PJ85431PF	Group 7	15 k (±5%)	0xDC/0xDD
41	PJ85431PF	Group 7	22 k (±5%)	0x3C/0x3D
42	PJ85431PF	Group 7	33 k (±5%)	0x7C/0x7D
43	PJ85431PG	Group 8	4.7 k (±5%)	0xFE/0xFF
44	PJ85431PG	Group 8	6.8 k (±5%)	0xBE/0xBF
45	PJ85431PG	Group 8	10 k (±5%)	0x9E/0x9F
46	PJ85431PG	Group 8	15 k (±5%)	0xDE/0xDF
47	PJ85431PG	Group 8	22 k (±5%)	0x3E/0x3F
48	PJ85431PG	Group 8	33 k (±5%)	0x7E/0x7F

For PJ85431, the SMBus or I²C slave address of this device is 10011000b (0x98h in HEX) in write mode, and 10011001b (0x99h in HEX) in read mode. If 2 or more of these devices in one SMBus are used, customers have to select thermal sensor with different slave address. Please contact Metawells sales for more information.

	A6	A5	A4	A3	A2	A1	A0	R/W
Read	1	0	0	1	1	0	0	1
Write	1	0	0	1	1	0	0	0

General Call Reset

The chip supports reset via the I²C/SMBus General Call address 0x00h (0000 0000b). The chip acks the General Call address and respond to the second byte. If the second byte is 0x06h (0000 0110b), the chip will perform software reset. This action will reset all registers to POR state, abort any conversion in progress, and clear the ALERT and THERM pins.

±1°C Remote and Local Temperature Sensor with Digital Interface In a MSOP-8P and DFN3x3-8 Package

Timeout

The chip supports SMBus timeout. If the clock is held low for longer than 30 ms (Typ.), the chip will reset its SMBus protocol and be ready for a new transmission.

SMBus Protocol

The chip supports four standard SMBus protocols Send Byte, Read Byte, Write Byte and Receive Byte, shown as below tables.

Write Byte

S	Slave Add	R/W	ACK	Reg Add	ACK	Reg Data	ACK	P
	1001100	0	0	XXh	0	XXh	0	

Read Byte

S	Slave Add	R/W	ACK	Reg Add	ACK	S	Slave Add	R/W	ACK	Reg Data	NACK	P
	1001100	0	0	XXh	0		1001100	1	0	XXh	1	

Send Byte

S	Slave Add	R/W	ACK	Reg Add	ACK	P
	1001100	0	0	XXh	0	

Receive Byte

S	Slave Add	R/W	ACK	Reg Add	NACK	P
	1001100	1	0	XXh	1	

Here S means SMBus Start to communication with master; P, means communication STOP.

Slave Add, means the chip's SMBus address.

Reg Add, means pointed Register Address.

Reg Data, means data to be written into register or read from register.

Compatible with I²C

The chip is compatible with both SMBus and I²C. And the major difference between SMBus and I²C is shown as below. For more information, refer to SMBus specification v2.0 and I²C specification v2.1.

- 1). this chip supports I²C fast mode (400 kHz) and standard mode (100 kHz), which can cover SMBus maximum frequency 100 kHz.
- 2). For SMBus protocol, the minimum frequency is 10 kHz. There is no such limitation for I²C.
- 3). For SMBus protocol, slave device will reset if hold clock at '0' longer than 30 ms. There is no timeout limitation for I²C.
- 4). ARA (Alert Response Address) general call is only valid interrupt in SMBus, not valid in I²C.

±1°C Remote and Local Temperature Sensor with Digital Interface In a MSOP-8P and DFN3x3-8 Package

ALERT Output

ALERT pin is an output pin with open drain structure, and it will be pulled low by internal circuits once ALERT trigger happens in normal working mode. It requires an external pull-up resistor. This pin indicates the measured temperature status. Any of below events happens; ALERT pin will be pulled-low. All below situations are called ALERT trigger.

- 1). local channel temperature exceeds that of high-limit register data;
- 2). local channel temperature equals or drops lower than that of low-limit register data;
- 3). remote channel temperature exceeds that of high-limit register data;
- 4). remote channel temperature equals or drops lower than that of low-limit register data;
- 5). remote diode is open/disconnect;

It is important to note the high/low-limit data format of all channels' registers, including local and remote should be kept the same as the format of temperature data. There are 2 kinds of formats, depends on RANGE bit is '0' or '1'.

Once ALERT trigger happened, ALERT pin will be asserted and the relevant register bit of STATUS register will be setup too. The status registers which will affect ALERT pin status, shown as below.

STATUS Register, Add: 0x02

BIT	ALERT	Name	Description
7	No	BUSY	1 – Means ADC is busy for temperature converting
6	Yes	LHIGH	1 – Means temperature in local channel is higher than that of LT_HAT register, alert active
5	Yes	LLOW	1 – Means temperature in local channel is lower than that of LT_LAT register, alert active
4	Yes	RHIGH	1 – Means temperature in remote channel is higher than that of RT_HAT register, alert active
3	Yes	RLOW	1 – Means temperature in remote channel is lower than that of RT_LAT, alert active
2	Yes	OPEN	1 – Means remote channel' diode is open/disconnected, alert active
1	No	RTHRM	1 – Means remote THERM alarm active
0	No	LTHRM	1 – Means local THERM alarm active

Configuration 1 Register, Add: 0x03 (R/W) & 0x09 (R/W)

BIT	ALERT	Name	Description
7	Yes	ALTMSK	0 – Disable to mask all ALERT interrupt function; 1 – Enable to mask all ALERT interrupt function;
6	Yes	STB	0 – The chip is active and working normally; 1 – The chip is in standby mode.
5	Yes	AL/TH	0 – Configure PIN6 as ALERT function; 1 – Configure PIN6 as THERM2 function;
4:3	No	0	No definition.
2	No	RANGE	0 – Temperature expression range is 0 to 127°C; 1 – Temperature expression range is -64 to 191°C.
1:0	No	0	No definition.

±1°C Remote and Local Temperature Sensor with Digital Interface In a MSOP-8P and DFN3x3-8 Package

CH_Mask Register, Add: 0x1F (R/W)

BIT	ALERT	Name	Description
7:2	No	RSV	Reserved bits, always 0 after reading.
1	Yes	RMSK	0 – Enable remote channel ALERT interrupt function; 1 – Mask remote channel ALERT interrupt function;
0	Yes	LMSK	0 – Enable local channel ALERT interrupt function; 1 – Mask local channel ALERT interrupt function;

Also the ALERT consecutive time number (ALT_CON [2:0], bit [3:1] of ALT_THM_CON register) will affect ALERT trigger. Default 1 time happen will cause ALERT trigger. If set consecutive time number as 4 (ALT_CON [2:0] =111) to prevent temperature changing noise, ALERT trigger only happens after 4 consecutive times trigger.

ALT_THM_CON Register, Add: 0x22

BIT	ALERT	NAME	Description
7	No	0	No definition, always '0' after reading.
6:4	No	THM_COM[2:0]	To setup the number of consecutive times to trig THERM condition, 000 – 1 001 – 2 011 – 3 111 – 4
3:1	Yes	ALT_CON[2:0]	To setup the number of consecutive times to trig ALERT condition, 000 – 1 001 – 2 011 – 3 111 – 4
0	No	0	No definition.

Also channel enable bits (bit [4:2] of Configuration 2 register, Add: 0x1A) will affect the ALERT trigger, since user can enable or disable each channel individually. All disabled channels will not cause ALERT trigger anymore. Generally ALERT trigger is earlier interrupt to inform MCU than THERM.

ALERT trigger cannot be released automatically even the measurement temperature comes back to temperature between high-limit and low-limit. It is released only by below conditions: Reading STATUS registers or/and SMBus ALERT Response (ARA).

- 1). the trigger conditions disappear, and Status registers are read already by host;
- 2). the trigger conditions disappear, the host sends the command of Alert Response Address via SMBus;

Alert Trigger Release Condition 1

Below Figure-17 shows the mechanism of the ALERT pin output .Once ALERT trigger happens, the ALERT pin will be asserted (active low). And ALERT pin can be released by reading STATUS registers [address 0x02] if the trigger conditions disappear.

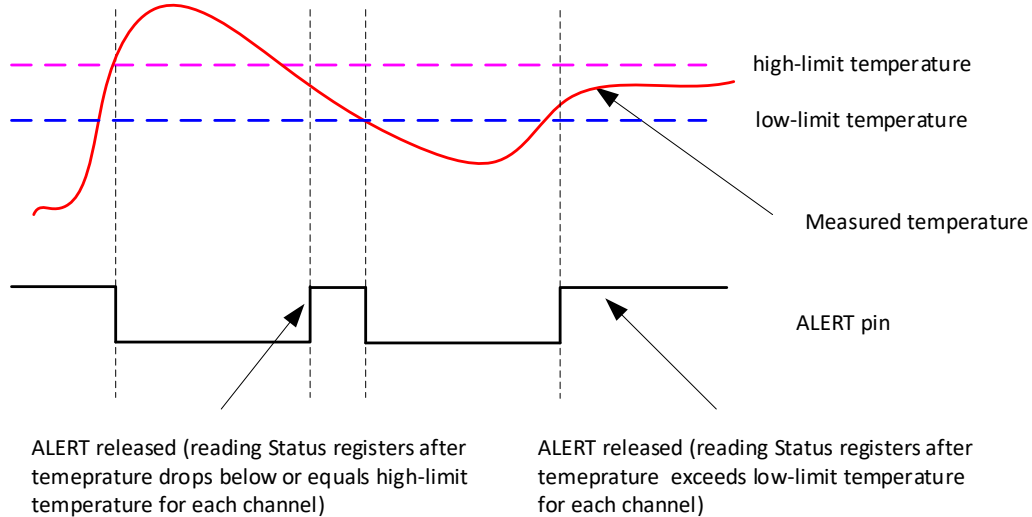

Figure-17. /ALERT pin output Diagram

Alert Trigger Release Condition 2

It can be used as a processor interrupt or as SMBus ALERT. When the master detects that ALERT pin is asserted, it will send Alert Response Address (ARA) to general address (00011001). All devices with active interrupts will respond with client address.

Below Figure-18 shows the mechanism of the ALERT output SMBus Alert mode. In this mode, the ALERT output is connected to the SMBus alert line which has more than one device connected to it. Through such an implementation, SMBus alert mode can assist the master in resolving which slave device generates an interrupt. When the measured temperature falls outside of the allowed range, the ALERT pin will be pulled low and the corresponding alert flags in Status Register will be set to 1. When SMBus ALERT Response Address (ARA) occurs from master (Alert Response Address is 0001100xb), the chip will generate and return its own address to the master. If the temperature never falls inside of the allowed range, the latched ALERT pin can release by the reset ALERT mask bit and the latched corresponding alert flags in Status Register can release by reading command for Status Register.

S	ARA Add	R/W	ACK	Slave Add	ACK	P
	0001100	1	0	1001 100xb	1	

**±1°C Remote and Local Temperature Sensor
with Digital Interface
In a MSOP-8P and DFN3x3-8 Package**

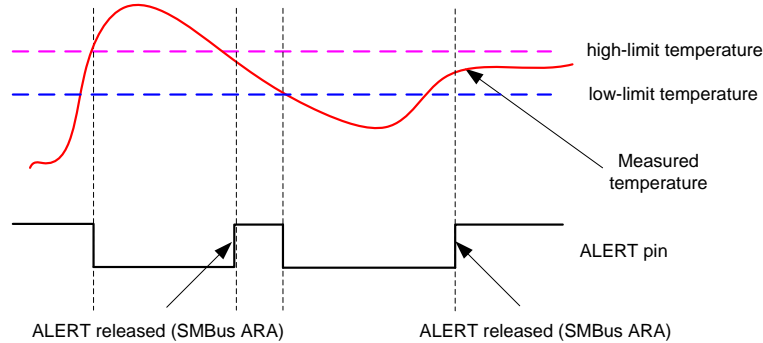

Figure-18. /ALERT pin in SMBus ARA

THERM Output

THERM pin is also an active low output with open drain. The THERM is asserted and pulled low when any of the measured temperatures exceeds the THERM limit temperature programmed by user in register address of 0x19, 0x20. Once THERM pin outputs low, it will remain asserted and will not be released until all measured temperature is lower than THERM limit minus THERM Hysteresis (also programmable in register address 0x21). When the THERM pin is asserted, THERM Status bits of STATUS and THERM_STATUS registers will be set respectively and will not be cleared until the THERM pin is de-asserted. THERM trigger cannot be masked, which is unlike ALERT trigger. Below Figure shows this mechanism. In general, THERM is later interrupt to inform MCU than ALERT.

PIN6 can be configured as 2nd THERM PIN (THERM2), by setting bit5 of Configuration 1 register as '1'. Once PIN6 is used as THERM2, only high-limit temperature is used as second THERM-limit temperature, and user can ignore low-limit temperature register data. THERM2 pin can be released once all channels temperature drops below high-limit temperature minus hysteresis temperature.

Channel	THERM pin		THERM2 pin	
	Threshold Register	Hysteresis Register	Threshold Register	Hysteresis Register
Local	0x20, Default: 0x55 [85°C]	0x21, Default: 0x0A [10°C]	0x0B[MSB] + 0x16[LSB], Default: 0x55 [85°C]	0x21, Default: 0x0A [10°C]
Remote	0x19, Default: 0x55 [85°C]	0x21, Default: 0x0A [10°C]	0x0D[MSB] + 0x13[LSB], Default: 0x55 [85°C]	0x21, Default: 0x0A [10°C]

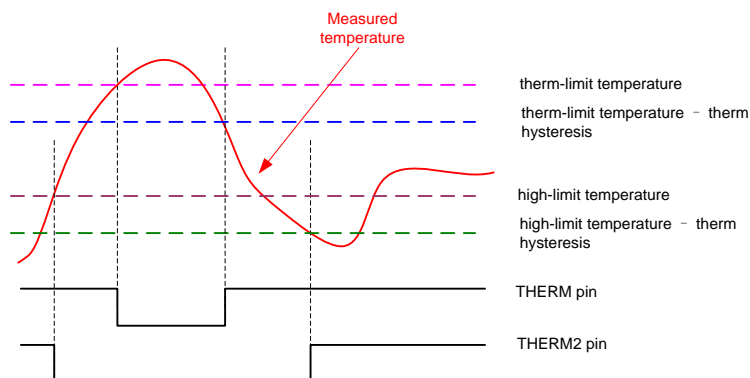

Figure-19. THERM pin and THERM2 pin output

Remote Diode Fault Alarm and Diode Selection

The chip can detect an open on remote channel, between DP and DN pins (e.g. external diode is open or disconnected). In each temperature measurement cycle, the chip checks diode fault for each external diode. When a diode open is detected by the chip, the ALERT pin is asserted (ALERT is enabled and NOT masked). The temperature data is 0x00(MSB) and 0x00(LSB) if diode is open before POR. The temperature data is kept as last time conversion if diode open happens after POR. Also OPEN bit of Status register will be set '1'. Once a diode fault disappears, the OPEN bit will be reset as '0', the temperature register gets back to the right data.

The chip is designed to measure both local and remote channels' temperature. For remote temperature sensing, the chip needs connection to an external diode, which could be a discrete diode or a discrete BJT (PNP type or NPN type) transistor with diode-connected. The external diode also can be substrate parasitic BJT transistor inside CPU, GPU or FPGA chips.

For remote channel, temperature accuracy mostly depends on external PN junction. It is better to select small-signal BJT transistor of proper performance with diode-connected. Proper performance includes below,

- 1). V_{be} is between 250 mV at 10 μA and 950 mV at 300 μA ;
- 2). Beta or current DC gain, is equal or larger than 30, if beta is smaller, user can use beta compensation feature to keep high temperature accuracy;
- 3). base resistance is below 100 ohm, user can use series resistance cancellation feature to keep high temperature accuracy by setting SRCEN bit as '1'.

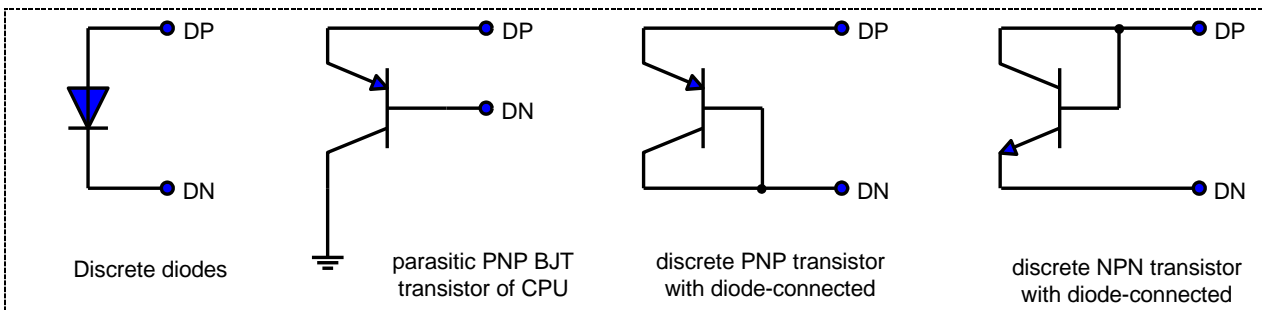

Figure-20. External Diode for Remote Channel

Beta Compensation

The physical fundamental of temperature sensing for remote channel is that temperature is proportion to emitter current ratio. If using a discrete PNP (i.e. 2N3906) or NPN (i.e. 2N3904) as remote diode (even emitter or collector short to GND), beta is large enough, over 100, there is only slight difference between emitter current ratio and collector current ratio, so temperature error caused by transistor connection or beta variation piece by piece is still too small to be ignored. For example, assuming beta = 100, beta variation = $\pm 10\%$, temperature error is about 0.13°C at $T = 85^{\circ}\text{C}$.

If using parasitic PNP transistor inside the CPU, GPU, FPGA or SoC chip as remote diode, collector is short to substrate, mostly the beta is below 1.0, temperature error caused by beta variation is significant, which cannot be ignored. For example, assuming beta = 0.45, beta variation = $\pm 10\%$, temperature error is about 7.21°C at $T = 85^{\circ}\text{C}$.

±1°C Remote and Local Temperature Sensor with Digital Interface In a MSOP-8P and DFN3x3-8 Package

More and more CPU, GPU, FPGA or SOC chips used advanced process with 45 nm geometry or below, the beta becomes smaller and smaller, temperature error caused by this should be corrected. The PJ85431 builds in beta compensation feature to eliminate temperature error caused by lower beta. It can automatically detect and select the right range for different chips by setting register. See “Beta Compensation Register section” for detail.

Series Resistance Cancellation

For remote channel temperature measurement, there is always parasitic resistance including PCB trace, metal resistance on the die (parasitic PNP of CPU, GPU, FPGA or SoC chip) or base resistance (discrete transistor) from remote diode to the chip DP and DN pins. The temperature measurement principle is to measure voltage by forcing different current, so equivalent series resistance will introduce temperature error. The PJ85431 builds in series resistance cancellation feature, which will eliminate temperature error caused by series resistance. It will automatically cancel this error by setting SRCEN bit as ‘1’. It allows maximum series resistance up to 1k ohm.

N-Factor Correction

For remote channel temperature sensing, the non-ideality coefficient is trimmed to 1.008. However not all transistors could be used as remote transistors are this exact value. The PJ85431 builds in N-Factor correction feature, to allow user to adjust this coefficient by setting register, which can correct temperature measurement error caused by non-ideality coefficient. Note that, different coefficient stands for different slope over full temperature range, and cause different error at different temperature. See N-Factor Correction Register section for detail.

POR

The chip uses volatile memory. To prevent unclear power-supply conditions, which could happen in system application, from corrupting the data in memory and causing unexpected situation, a POR voltage detector monitors V_{CC} . When V_{CC} rises above threshold voltage (1.2 V in typical), the logic blocks begin operating. Then the chip block will work normally along with V_{CC} rising high enough gradually.

UVLO

The chip senses continuously supply voltage (VCC pin) when V_{CC} has reached a minimum working voltage. Once V_{CC} drops below 2.40 V in typical, the chip does not perform temperature conversion anymore. The last temperature data is used for the temperature measurement result.

Applications Information

How to Improve Temperature Accuracy

The temperature measurement of the chip is based on semiconductor physics principle. Forward voltage of diode is a function of temperature. The formula is shown as below.

$$V_F = \frac{kT}{q} \ln\left(\frac{I_F}{I_S}\right)$$

Here,

V_F – forward voltage

I_F – forward current

I_S – reverse saturation current

k – Boltzmann constant

T – Temperature in K

q – Electric charge constant

To cover wide temperature range, i.e. -40°C to 125°C, a very small voltage variation is corresponding to every degree C temperature change. For this chip, 200 μ V voltage between DP and DN pin stands for about 1°C. Metawells has applied many ways to improve measurement accuracy in chip circuits design, such as compensation, trimming etc. In real system design, however, some factors that can increase measurement error need to be considered. Most issues that usually occur are highlighted as below.

Serial Resistor (R_S), Differential Capacitor (C_d) of Remote Channel

In most applications, the remote diode could be located noise environment. Generally 200 μ V stands for about 1°C, any common-mode noise between DP and DN pin will cause temperature measurement error. The better way to use serial resistor (R_S) plus Differential Capacitor (C_d) to filter noise coupled to DP, DN wire. The sensor chip built-in serial resistor cancellation circuits which can remove the temperature measurement error caused by R_S . The maximum resistance does not exceed 1.0 kohm for R_S . For the differential capacitor, it will affect setup and sampling time of AD converter, so the maximum capacitance does not exceed 1000 pF. For example, $R_S = 50$ ohm, $C_d = 100$ pF. If the remote channel is NOT used, it is better to short DP and DN pins together.

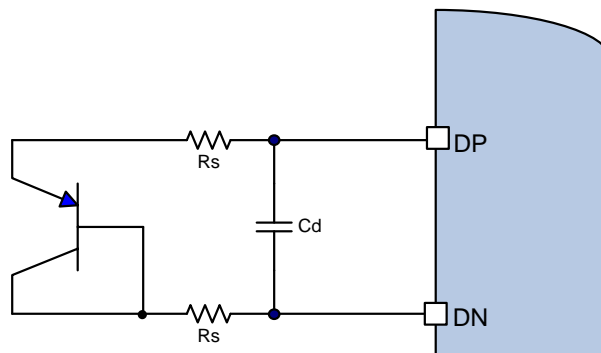

Figure- 21. R_S and C_d for Remote Channel

Thermal Response Time

It is very necessary to wait enough time for obvious temperature changing of target due to thermal time constant. Enough time is still needed for the target to reach thermal equilibrium, even forcing temperature transient into target object. For the chip soldered on the PCB with almost same size as MSOP-8P package, it will take about 20 seconds to reach thermal equilibrium under 1°C accuracy after putting into oil bath with 100°C suddenly from room temperature. For remote channel, if using a discrete transistor as thermal diode, the package of transistor is another important consideration which could affect thermal response. For examples, using 2N3904 as thermal diode, SOT-23 package has better thermal contact than TO-92 package.

Self-heating

For local sensor, self-heating could affect temperature measurement accuracy. It always brings positive error. It could be estimated as below steps.

Step 1, Estimating the chip power consumption, caused by average operating current and sink current at /ALERT pin, /THERM pin. For example,

$$Pd1 = V_{CC} \times I_{AOC} = 5.0 \text{ V} \times 45 \text{ } \mu\text{A} = 225 \text{ } \mu\text{W}$$

(Assuming V_{CC} is 5.0 V, conversion rate is 1 Hz.)

$$Pd2 = V_{OL} \times I_{SINK} = 0.1 \text{ V} \times 0.5 \text{ mA} \times 2 = 0.1 \text{ mW}$$

(Assuming in normal operating, both /ALERT pin and /THERM pins are active, and pull-up resistors are 10 k)

$$P_{dtotal} = Pd1 + Pd2 = 225 \text{ } \mu\text{W} + 0.1 \text{ mW} = 325 \text{ } \mu\text{W}$$

Step 2, Estimating junction temperature error caused by power consumption,

$$\Delta T_j = P_{dtotal} \times \Theta_{J-A} = 325 \text{ } \mu\text{W} \times 140 \text{ } ^\circ\text{C/W} = 45.5 \text{ m}^\circ\text{C} = 0.04^\circ\text{C}, \text{ which is too small to be ignored.}$$

(For this package, thermal resistance of junction-to-air is 140 °C/W.)

PCB Layout

Cautions below are important to improve temperature measurement in PCB layout design.

Device placement

It is better to place the chip away from any thermal source (e.g. power device in board), high speed digital bus (e.g. memory bus), coil device (e.g. inductors) and wireless antenna (e.g. Bluetooth, WiFi, and RF). It is recommended to place the chip close to the remote diode. The better way is to use serial resistor (R_s) plus differential capacitor (C_d) for each remote channel to filter noise.

DP, DN Route in PCB

It is better to draw the traces of DP and DN net list as a pair trace and to make sure that the two are always kept with the same distance and the same layer in PCB board. Also it is better NOT to change PCB layer for this pair trace, which means to keep trace to the same layer as the chip and remote diode.

The recommended trace width of DP, DN pair trace is 5mil.

**$\pm 1^{\circ}\text{C}$ Remote and Local Temperature Sensor
with Digital Interface
In a MSOP-8P and DFN3x3-8 Package**

Twisted cable and shield

Another method is to use ground shield around the DP, DN pair trace, which could reduce digital noise.

Twisted cable with shield is recommended for long distance temperature measurement that uses a discrete diode as the remote sensor. Shield is shorted to ground.

Leakage from DP/DN to GND or V_{CC}

Another possibility caused temperature error is leakage path from DP/DN to GND or from DP/DN to V_{CC} . The leakage path caused by tight layout, assembly, splashing unclear water or some reason during production.

PACKAGE OUTLINE DIMENSION – MSOP-8P

MSOP-8P Unit (mm)

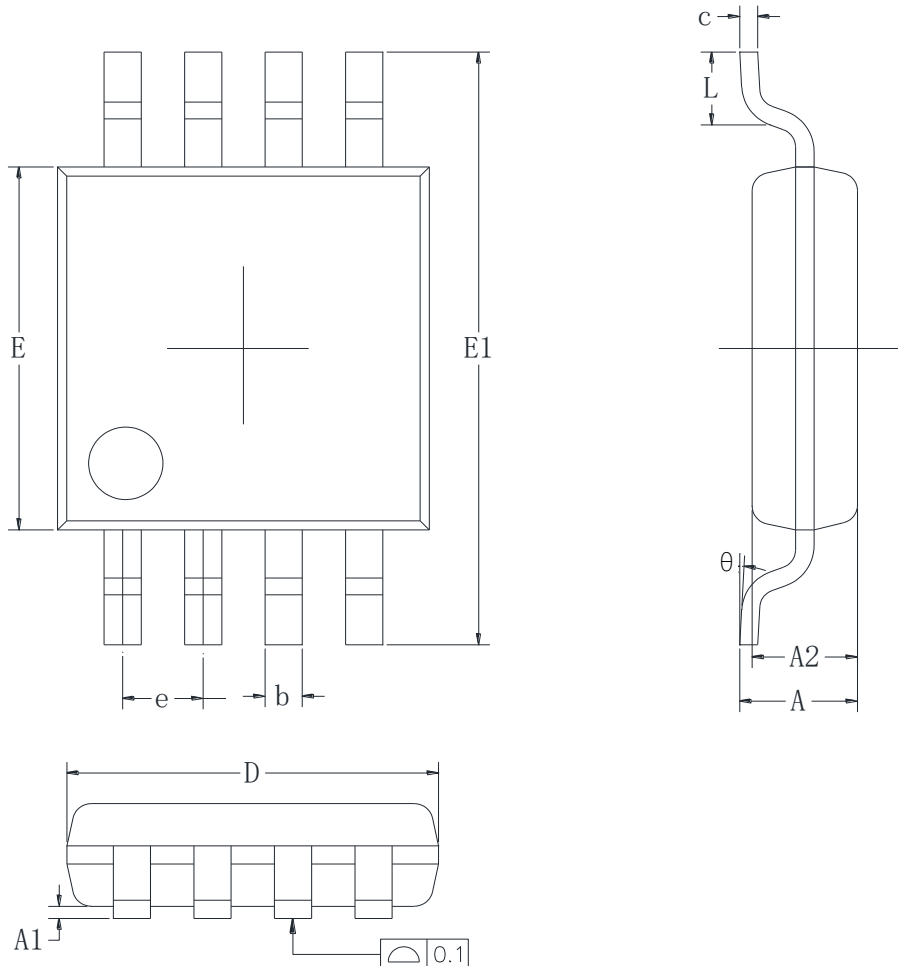

Symbol	Dimensions in Millimeters		Dimensions in Inches	
	Min.	Max.	Min.	Max.
A	0.820	1.100	0.032	0.043
A1	0.020	0.150	0.001	0.006
A2	0.750	0.950	0.030	0.037
b	0.250	0.380	0.010	0.015
c	0.090	0.250	0.004	0.010
D	2.900	3.100	0.114	0.122
E	2.900	3.100	0.114	0.122
E1	4.700	5.100	0.185	0.201
e	0.650 (BSC)		0.026 (BSC)	
L	0.400	0.800	0.016	0.031
θ	0°	8°	0°	8°

Recommend Land Pattern Layout – MSOP-8P

MSOP-8P Unit (mm)

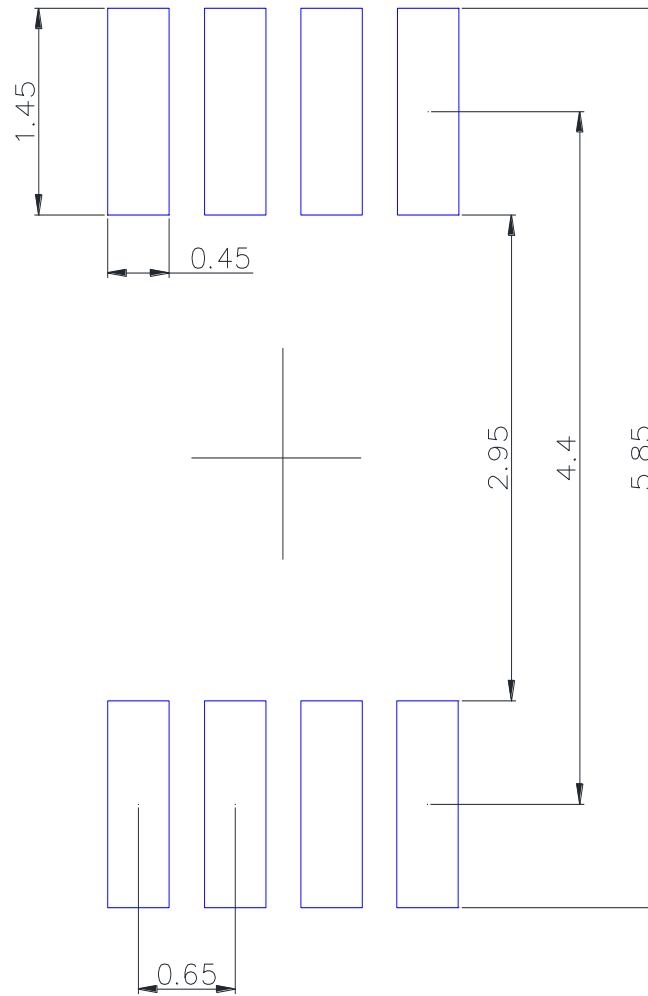

Note:

1. All dimensions are in millimeter
2. Recommend tolerance is within ± 0.1 mm
3. Change without notice

PACKAGE OUTLINE DIMENSION – DFN3x3-8

DFN3x3-8 Unit (mm)

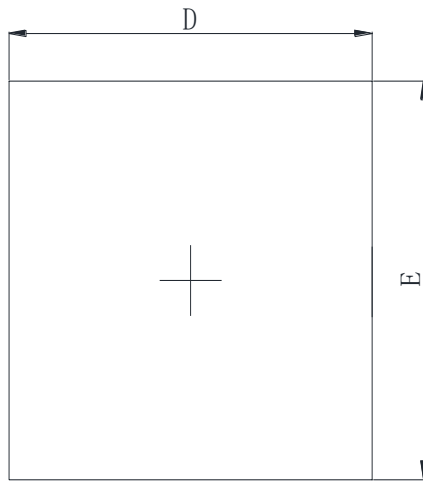
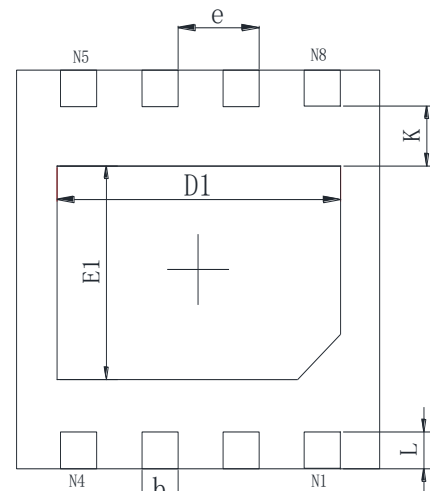
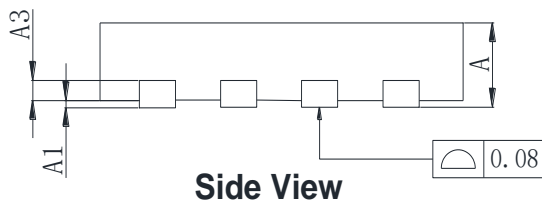

Top View

Bottom View

Side View

Symbol	Dimensions in Millimeters		Dimensions in Inches	
	Min.	Max.	Min.	Max.
A	0.700	0.800	0.028	0.031
A1	0.000	0.050	0.000	0.002
A3	0.203REF.		0.008REF	
D	2.900	3.100	0.114	0.122
E	2.900	3.100	0.114	0.122
D1	2.200	2.600	0.087	0.102
E1	1.400	1.800	0.055	0.071
k	0.250MIN.		0.010REF	
b	0.250	0.350	0.010	0.014
e	0.650TYP.		0.026TYP	
L	0.300	0.500	0.012	0.020

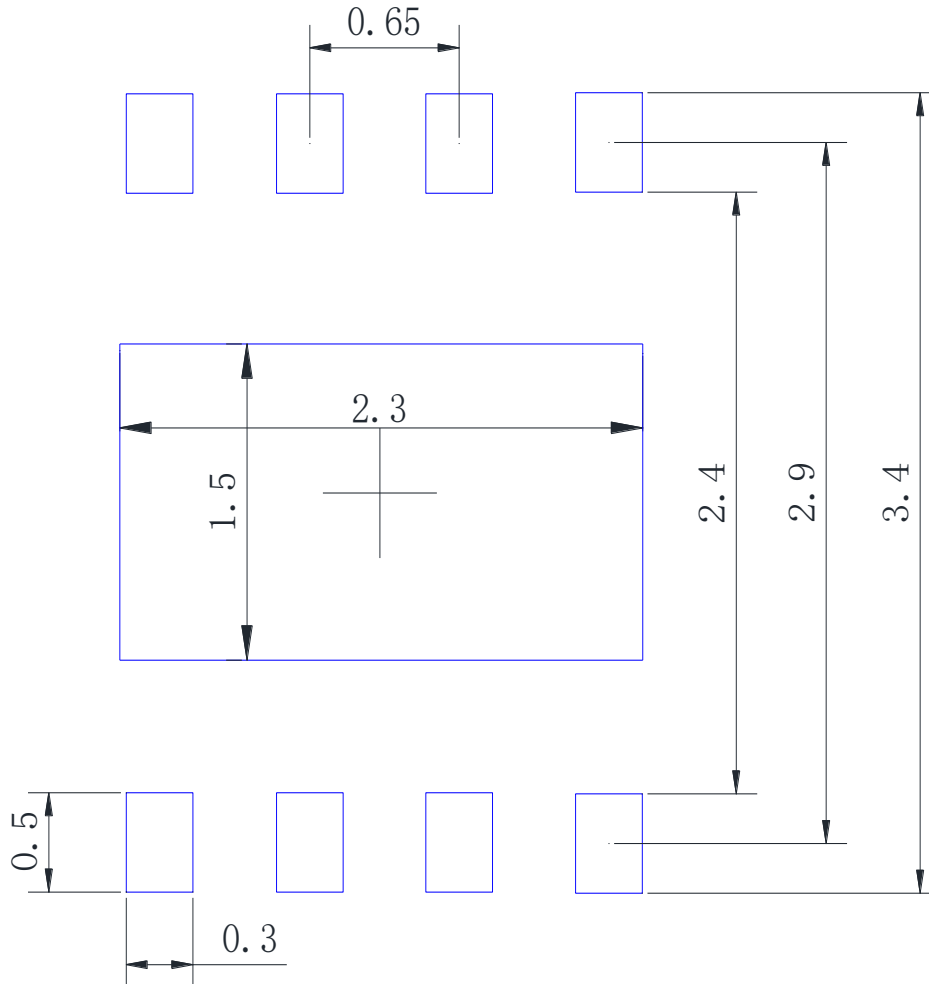
Note : Pin 1 shape for thermal pad on backside is not limited to bevel, it can be a notch or arch

PACKAGE OUTLINE DIMENSION – DFN3x3-8

DFN3x3-8 Unit (mm)



Note:

1. All dimensions are in millimeter
2. Recommend tolerance is within $\pm 0.1\text{mm}$
3. If the thermal pad is not necessary, designer can leave the land pattern area blank
4. Change without notice

Disclaimer

- Reproducing and modifying information of the document is prohibited without permission from Metawells International Inc..
- Metawells International Inc. reserves the rights to make changes of the content herein the document anytime without notification. Please refer to our website for the latest document.
- Metawells International Inc. disclaims any and all liability arising out of the application or use of any product including damages incidentally and consequentially occurred.
- Metawells International Inc. does not assume any and all implied warranties, including warranties of fitness for particular purpose, non-infringement and merchantability.
- Applications shown on the herein document are examples of standard use and operation. Customers are responsible in comprehending the suitable use in particular applications. Metawells International Inc. makes no representation or warranty that such applications will be suitable for the specified use without further testing or modification.
- The products shown herein are not designed and authorized for equipments requiring high level of reliability or relating to human life and for any applications concerning life-saving or life-sustaining, such as medical instruments, transportation equipment, aerospace machinery et cetera. Customers using or selling these products for use in such applications do so at their own risk and agree to fully indemnify Metawells International Inc. for any damages resulting from such improper use or sale.
- Since Metawells uses lot number as the tracking base, please provide the lot number for tracking when complaining