

PJ85775 Datasheet

$\pm 0.5^{\circ}\text{C}$ Digital Temperature Sensor with Digital Interface In a SOP-8P/MSOP-8P Package

Version: Rev.1.0

Release Date: 2025-11-21

General Description

The PJ85775 is a digital temperature sensor with $\pm 0.5^{\circ}\text{C}$ accuracy. Temperature data can be read out directly via digital interface (compatible with SMBus, I²C or 2-wire) by MCU, Bluetooth Chip or SoC chip.

PJ85775 supports I²C communication with speed up to 400 kHz. Each chip is specially calibrated for $\pm 0.5^{\circ}\text{C}$ (Max.) accuracy over 0°C to 50°C range in factory before shipment to customers. There is no need for re-calibration anymore for $\pm 0.5^{\circ}\text{C}$ accuracy.

It includes a high precision band-gap circuit, a 12-bit analog to digital converter that can offer 0.0625°C resolution, a calibration unit with non-volatile memory, and a digital interface block.

It includes a band-gap circuit, an Analog to Digital converter, a calibration unit with non-volatile memory and a digital interface block. It has ALERT logic output pin with open drain structure, which is selectable for active low or high by programming. ALERT response is compatible with SMBus ALERT Response Address (ARA).

PJ85775 can be used as standalone thermostat. Available Package : SOP-8P and MSOP-8P.

Features

- ◆ Operation Voltage : 1.75 V to 5.5 V
- ◆ Average Quiescent Current : 3.0 μA (Typ.) at 1.0 con/s
- ◆ Standby Current : 1.0 μA (Typ.)
- ◆ Temperature Accuracy without calibration :
 - $\pm 0.5^{\circ}\text{C}$ from 0°C to 50°C
 - $\pm 1.0^{\circ}\text{C}$ from -20°C to 85°C
 - $\pm 1.5^{\circ}\text{C}$ from -40°C to 125°C
- ◆ 12 bit ADC for 0.0625°C resolution
- ◆ Compatible with SMBus, 2-wire and I²C interface
- ◆ Compatible industry LM75 with performance improved
- ◆ Programmable Over/Under Temperature
- ◆ Programmable Active Low or High for ALERT pin
- ◆ Support SMBus ALERT Response Address (ARA)
- ◆ Generate 32 different slave address by setup A0, A1, A2 pin
- ◆ Temperature Range: -40°C to 125°C

Applications

- ◆ Smart HVAC System
- ◆ Portable Device
- ◆ Thermal Management

Ordering Information

Ordering Information

Order PN	Accuracy	Green ⁽¹⁾	Package	Marking ID	Packing	MPQ	Operation Temperature
PJ85775P	±0.5°C	Halogen free	SOP-8P	PJ85775 PYMDNN	Tape & Reel	4,000	-40°C ~ +125°C
PJ85775M	±0.5°C	Halogen free	MSOP-8P	A2 YM DNN	Tape & Reel	3,000	-40°C ~ +125°C

Note:

(1) MetaWells can meet RoHS 2.0/REACH requirement. So most package types MetaWells offers only states halogen free, instead of lead free.

Marking Information

Marking ID	Package	Definition
PJ85775 PYMDNN	SOP-8P	PJ85775: Product code P: Package code Y: Year code M: Month code D: Day code NN: Serial No.
A2 YM DNN	MSOP-8P	A2: Product code Y: Year code M: Month code D: Day code NN: Serial No.

Pin Configuration

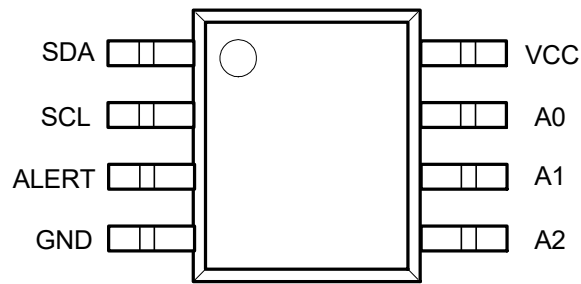

SOP-8P / MSOP-8P (Top View)

Pin Description

Pin		Function
Num	Name	
1	SDA	Digital interface data input or output pin, need a pull-up resistor to VCC.
2	SCL	Digital interface clock input pin, need a pull-up resistor to VCC.
3	ALERT	To Indicate ALERT of over or under Temperature programmed by setting T_{HIGH} / T_{LOW} register, it is open drain output with programmable active low or high. Need a pull-up resistor to VCC in application.
4	GND	Ground pin.
5	A2	Address selection pins, the chip can be defined total 32 different slave address by connecting these pins to GND, VCC, SCL or SDA pin respectively. Do not leave this pins open. See " Slave Address " for detail.
6	A1	
7	A0	
8	VCC	Power supply input pin, using 0.1 uF low ESR ceramic capacitor to ground

Application Schematic

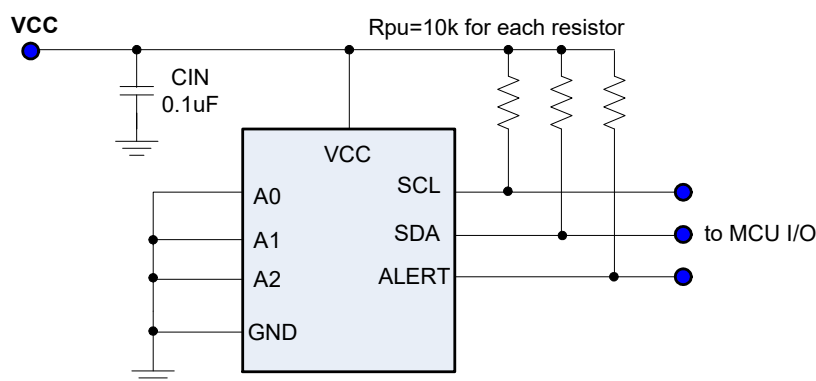

Function Block

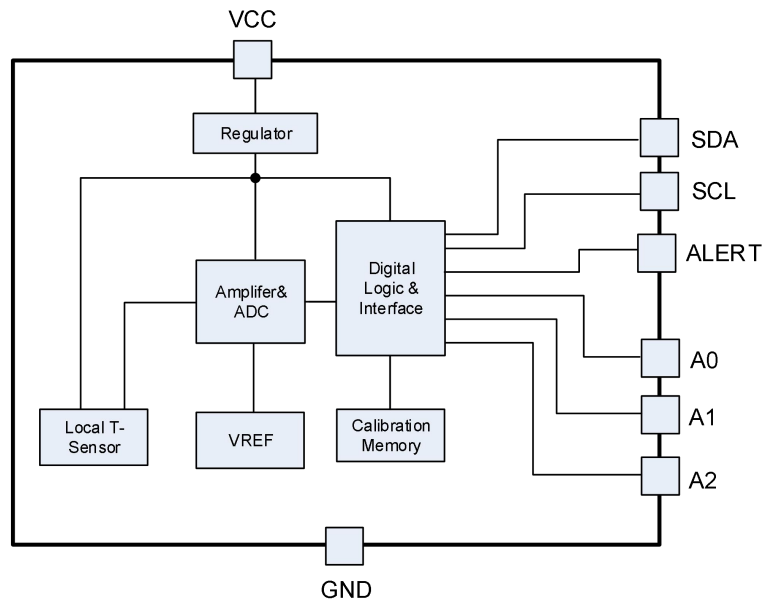

Absolute Maximum Ratings

Over operating free-air temperature range (unless otherwise noted) ⁽¹⁾

Parameter		Min	Max	Units
V _{CC} to GND	Supply Voltage	-0.3	7	V
V _{SDA} /V _{SCL} /V _{A0} /V _{A1} /V _{A2} to GND	SDA, SCL, A0, A1, A2 Voltage	-0.3	7	V
V _{ALERT} to GND	ALERT Voltage	-0.3	7	V
T _J	Operating junction temperature range	-50	150	°C
T _{STG}	Storage Temperature Range	-65	150	°C
T _{LEAD}	Lead Temperature (Soldering, 10 Seconds)	260		°C

(1) Stresses beyond those listed under absolute maximum ratings may cause permanent damage to the device. These are stress ratings only, and functional operation of the device at these or any other conditions beyond those indicated under recommended operating conditions is not implied. Exposure to absolute-maximum-rated conditions for extended periods may affect device reliability.

Handling Ratings

Parameter	Definition	Min	Max	Units
ESD ⁽¹⁾	Human Body Model (HBM) ESD stress voltage ⁽²⁾	-4	4	kV
	Charged Device Model (CDM) ESD stress voltage ⁽³⁾ , all pins	-1	1	kV

(1) Electrostatic discharge (ESD) to measure device sensitivity and immunity to damage caused by assembly line electrostatic discharges into the device.

(2) Level listed above is the passing level per ANSI, ESDA, and JEDEC JS-001. JEDEC document JEP155 states that 500-V HBM allows safe manufacturing with a standard ESD control process.

(3) Level listed above is the passing level per EIA-JEDEC JESD22-C101. JEDEC document JEP157 states that 250-V CDM allows safe manufacturing with a standard ESD control process.

Recommended Operating Conditions

Parameter		Min	Max	Units
V _{CC}	Supply Voltage	1.75	5.5	V
T _A	Operating Ambient temperature	-40	125	°C

Electrical Characteristics

Test Condition: $C_{IN} = 0.1 \mu F$, $V_{CC} = 3.3 V$, $T_A = 40$ to $125^\circ C$ unless otherwise specified, all limits are 100% test at $T_A = 25^\circ C$. ⁽¹⁾

Parameter		Test Conditions	Min	Typ	Max	Units
V_{CC}	Supply voltage range		1.75		5.5	V
T_{AC}	Temperature Accuracy	$T_A = 0$ to $50^\circ C$	-0.5		0.5	$^\circ C$
		$T_A = -20$ to $85^\circ C$	-1.0		1.0	$^\circ C$
		$T_A = -40$ to $125^\circ C$	-1.5		1.5	$^\circ C$
$T_{RESOLUTION}$	Temperature Resolution			0.0625		$^\circ C$
I_{AOC}	Average Operating Current	$V_{IN} = 3.3 V$, 1.0 con/s		3.0	4.5	μA
I_{SD}	Shutdown Current	STB bit = 1, force SDA/SCL to VCC or GND		1.0	3.0	μA
V_{ODL}	Open Drain Output Voltage	ALERT pin, sink 5 mA	0		0.5	V
I_{ODL}	Open Drain Leakage	ALERT pin Leakage	-1.0		1.0	μA
T_{CON}	Conversion time	From active to finish completely		30		mS
DIGITAL INTERFACE						
C_{IL}	Logic Input Capacitance	SDA, SCL pin		3.0		pF
V_{IH}	Logic Input High Voltage	SDA, SCL pin	$0.7xV_{CC}$		$V_{CC}+0.3$	V
V_{IL}	Logic Input Low Voltage	SDA, SCL pin	-0.3		$0.3xV_{CC}$	V
I_{INL}	Logic Input Current	SDA, SCL pin	-1.0		1.0	μA
I_{OLS}	Logic Output Sink Current	SDA, ALERT pin forced 0.2 V		5.0		mA
f_{CLK}	SCL frequency	Fast Mode	1		400	KHz
		High Speed Mode	0.001		3	MHz
t_{LOW}	Clock low period time		1300			nS
t_{HIGH}	Clock high period time		600			nS
t_{BUF}	Bus free time	Between Stop and Start condition	1200			nS
$t_{HD:STA}$	Hold time after Start condition		600			nS
$t_{SU:STA}$	Repeated Start condition setup time		600			nS
$t_{SU:STO}$	Stop condition setup time		600			nS
$t_{HD:DAT}$	Data Hold time		100			nS
$t_{SU:DAT}$	Data Setup time		100			nS
t_F	Clock/Data fall time				300	nS
t_R	Clock/Data rise time				1000	nS

(1) All devices are 100% production tested at $T_A = +25^\circ C$; all specifications over the automotive temperature range is guaranteed by design, not production tested.

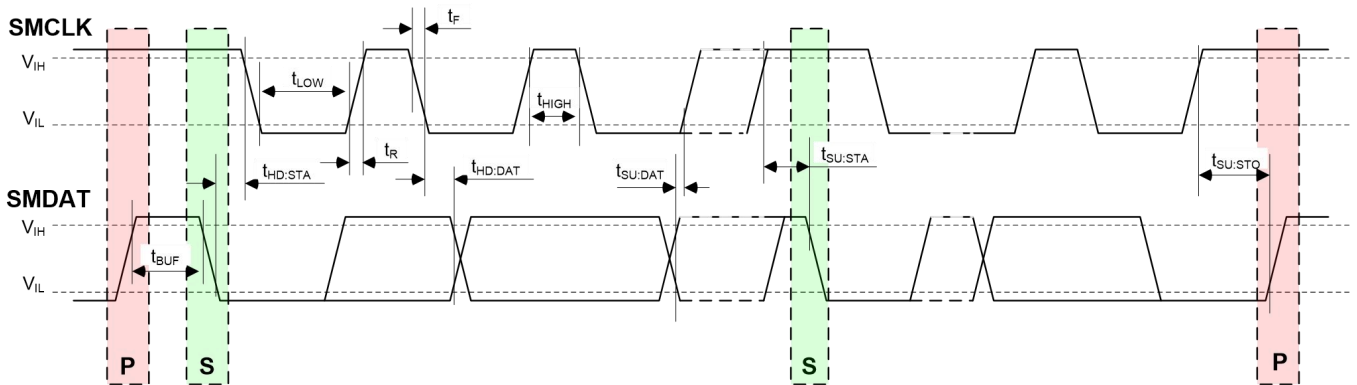

Figure-1. SMBus / I²C Timing Diagram

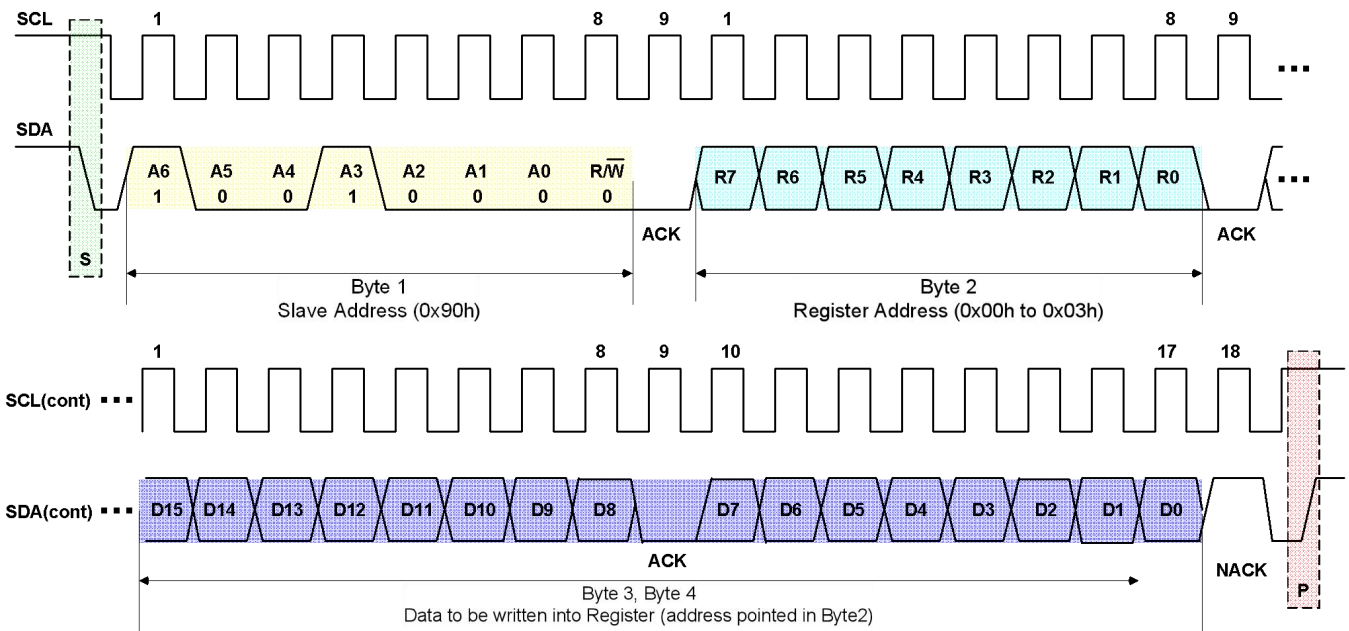

Figure-2. SMBus / I²C Write Word (2-Bytes) Timing Diagram

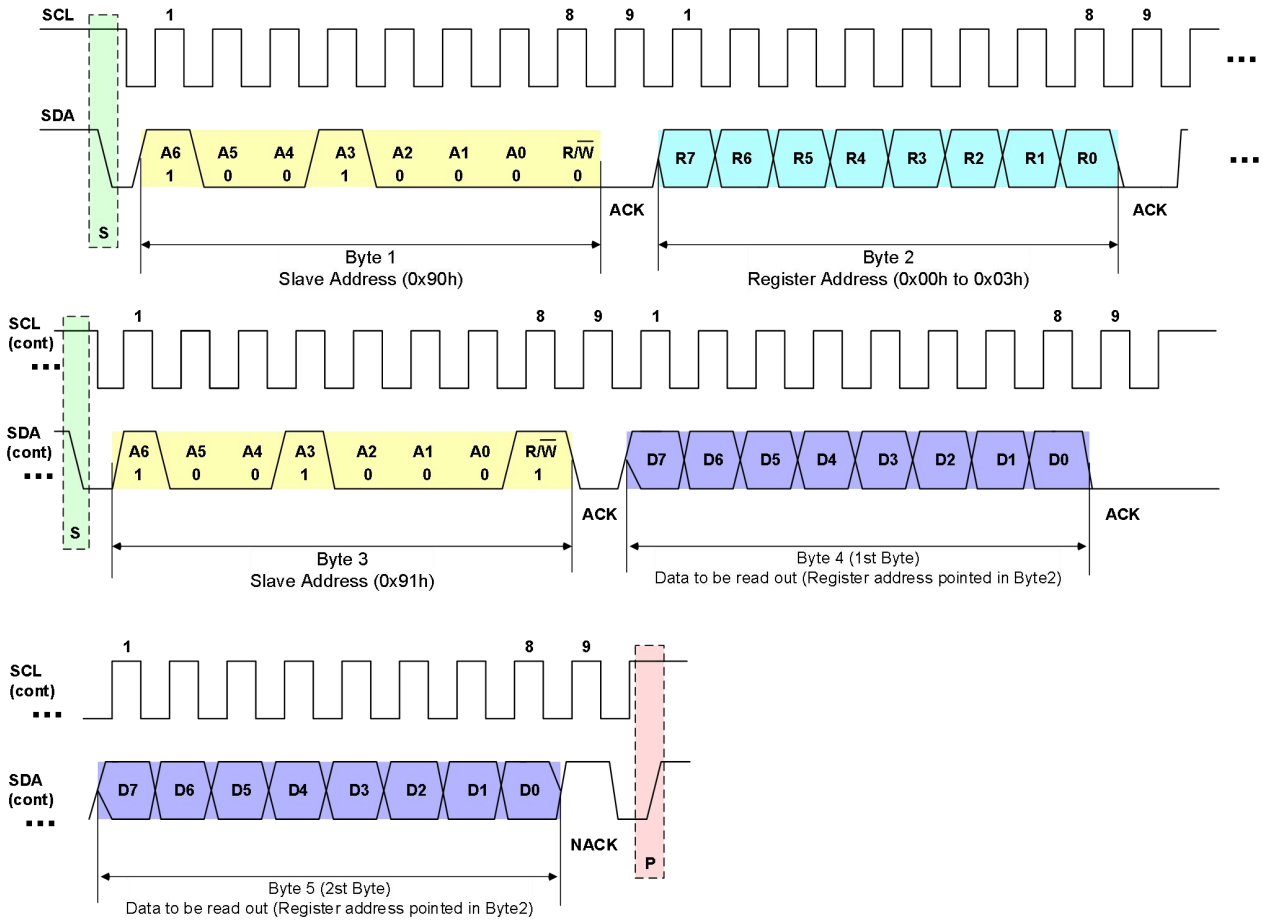

Figure-3. SMBus / I²C Read Word (2-Bytes) Timing Diagram

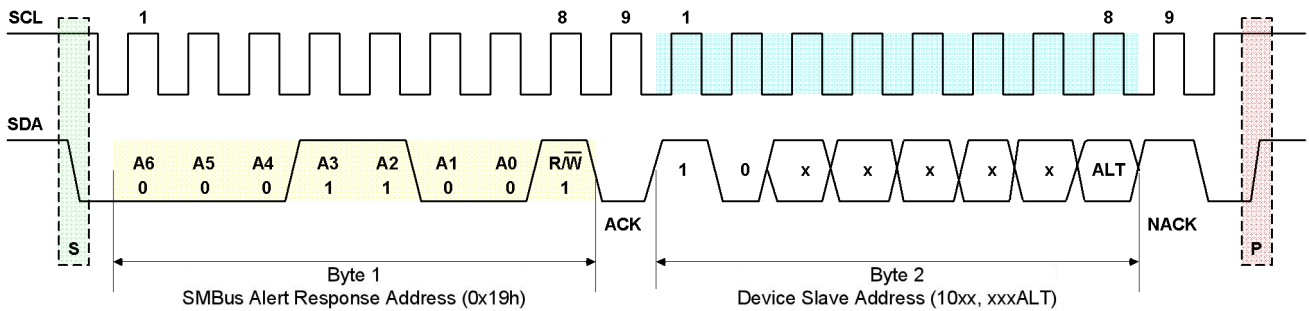

Figure-4. SMBus ALERT Response Diagram

Characteristics ($V_{CC} = 3.0\text{ V} / 5.0\text{ V}$)

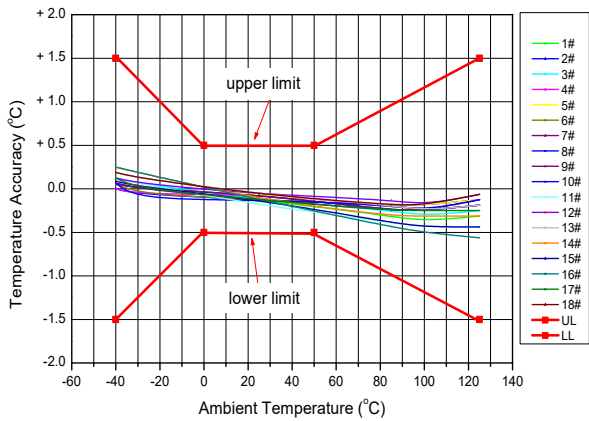

Figure-5. Temperature Accuracy vs. Temperature

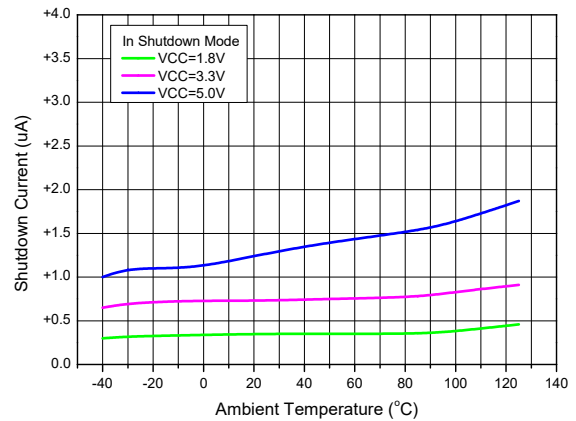

Figure-6. Shutdown Current vs. Temperature

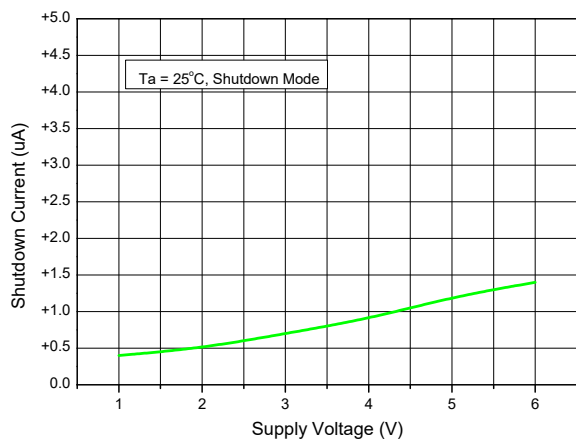

Figure-7. Shutdown current vs. Supply Voltage

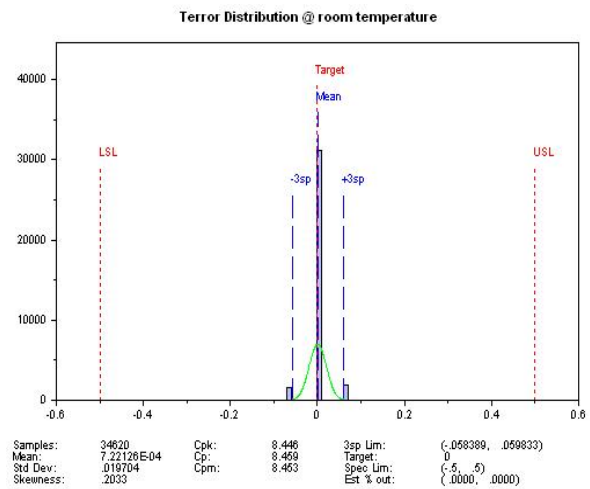

Figure-8. Temperature Error Distribution

Function Description

Overview

The chip can sense temperature and convert it into digital data by a 12-bit ADC. Also the chip supports programmable high-/low-limit temperature settings. If the measured temperature meets or exceeds the high-limit temperature, ALERT pin will be asserted (be set low or high, depending on POL bit of configuration register). Once the measured temperature goes below the low-limit temperature (programmable by user), ALERT pin will be released (comparator mode).

Digital Output of Temperature Data

The temperature measurement data is stored in read only temperature register. The temperature register is in 12-bit binary format (set EM bit as '0') or 13-bit binary format (set EM bit as '1') with 2-Bytes. This 2-Bytes temperature data must be read at the same time in each reading cycle, 1st-Byte is MSB followed by 2nd-Byte, the LSB. The relationship between temperature data in Celsius degree and binary data is shown as below tables.

Table-1. 12-bit Temperature Data (EM bit = 0)

Temperature (°C)	12-bit Digital Output (HEX)	12-bit Digital Output (BIN)
+128.000	0x7FF0	0 1 1 1, 1 1 1 1, 1 1 1 1 (0 0 0 0)
+127.9375	0x7FF0	0 1 1 1, 1 1 1 1, 1 1 1 1 (0 0 0 0)
+100.000	0x6400	0 1 1 0, 0 1 0 0, 0 0 0 0 (0 0 0 0)
+25.000	0x1900	0 0 0 1, 1 0 0 1, 0 0 0 0 (0 0 0 0)
+0.250	0x0040	0 0 0 0, 0 0 0 0, 0 1 0 0 (0 0 0 0)
0.000	0x0000	0 0 0 0, 0 0 0 0, 0 0 0 0 (0 0 0 0)
-0.0625	0xFFFF0	1 1 1 1, 1 1 1 1, 1 1 1 1 (0 0 0 0)
-0.250	0xFFC0	1 1 1 1, 1 1 1 1, 1 1 0 0 (0 0 0 0)
-25.000	0xE700	1 1 1 0, 0 1 1 1, 0 0 0 0 (0 0 0 0)

Table-2. 13-bit Temperature Data (EM bit = 1)

Temperature (°C)	13-bit Digital Output (HEX)	8-bit Digital Output (BIN) (MSB) 1 st Byte	5-bit Digital Output (BIN) (LSB) 2 nd Byte
+150.000	0x4B01	0 1 0 0, 1 0 1 1	0 0 0 0, 0 (0 0 1)
+128.000	0x4001	0 1 0 0, 0 0 0 0	0 0 0 0, 0 (0 0 1)
+127.9375	0x3FF9	0 0 1 1, 1 1 1 1	1 1 1 1, 1 (0 0 1)
+100.000	0x3201	0 0 1 1, 0 0 1 0	0 0 0 0, 0 (0 0 1)
+25.000	0x0C81	0 0 0 0, 1 1 0 0	1 0 0 0, 0 (0 0 1)
+0.250	0x0021	0 0 0 0, 0 0 0 0	0 0 1 0, 0 (0 0 1)
0.000	0x0001	0 0 0 0, 0 0 0 0	0 0 0 0, 0 (0 0 1)
-0.0625	0xFFFF9	1 1 1 1, 1 1 1 1	1 1 1 1, 1 (0 0 1)
-0.250	0xFFE1	1 1 1 1, 1 1 1 1	1 1 1 0, 0 (0 0 1)
-25.000	0xF381	1 1 1 1, 0 0 1 1	1 0 0 0, 0 (0 0 1)

Temperature Higher than 128

When temperature is higher than 128°C, it can be expressed in binary register data by setting EM bit as '1', shown as above Table-2. In extended format, the resolution of AD converter does not change, but '+128' bit is added. For example, 12-bit format for 100°C is 0x6400, in which 0x64 is from 1st Byte, and 0x00 is from 2nd Byte. 13-bit format for 100°C is 0x3201, in which 0x32 is from 1st Byte, and 0x01 is from 2nd Byte. The default for EM bit is '0' after Power-on reset.

Register Map

The chip has 4 registers assigned address from 0x00 to 0x03, and there are 2 Bytes (1st Byte and 2nd Byte), total 16 bits for each register, shown as below table.

Table-3. Register Map

Register Address	Register Name	Attribu tion	Default Data	BIT							
				7	6	5	4	3	2	1	0
0x00 ⁽¹⁾	Temp_MSB (1 st Byte)	R/O	N/A	Temp_Data [11:4]							
	Temp_LSB (2 nd Byte)	R/O	N/A	Temp_Data [3:0]							
0x01	Config_MSB (1 st Byte)	R/W	0x00	OS	CR1	CR0	F1	F0	POL	ALTM	SD
	Config_LSB (2 nd Byte)	R/W	0x20	0	0	AL	EM	0	0	0	0
0x02 ⁽¹⁾	Low_Temp_Set_MSB (1 st Byte)	R/W	0x4B	Low_Temp_Setup_Data [11:4]							
	Low_Temp_Set_LSB (2 nd Byte)	R/W	0x00	Low_Temp_Setup_Data [3:0]							
0x03 ⁽¹⁾	High_Temp_Set_MSB (1 st Byte)	R/W	0x50	High_Temp_Setup_Data [11:4]							
	High_Temp_Set_LSB (2 nd Byte)	R/W	0x00	High_Temp_Setup_Data [3:0]							

Note:

- (1) if set EM as '1', Temp data is expressed in 13-bit format, 1st Byte, 8 bits data [12:5] is used as MSB, and 2nd Byte, 5 bits data [4:0] in left justified is used as LSB.

Register Description

Temp_Data, Temperature Data

- Register Address: 0x00
- Register Attribution: Read only
- Default Data: N/A

BIT (1 st Byte)	7	6	5	4	3	2	1	0
Name: Temp_MSB (1 st Byte)	Temp_Data[11:4]							
Temperature Data (°C) [12-bit]	SIGN	64	32	16	8	4	2	1
12-bit format	T11	T10	T9	T8	T7	T6	T5	T4
Temperature Data (°C) [13-bit]	(SIGN)	(128)	(64)	(32)	(16)	(8)	(4)	(2)
13-bit format	(T12)	(T11)	(T10)	(T9)	(T8)	(T7)	(T6)	(T5)

BIT (2 nd Byte)	7	6	5	4	3	2	1	0
Name: Temp_LSB (2 nd Byte)	Temp_Data[3:0]							
Temperature Data (°C) [12-bit]	0.5	0.25	0.125	0.0625	0	0	0	0
12-bit format	T3	T2	T1	T0	0	0	0	0
Temperature Data (°C) [13-bit]	(1)	(0.5)	(0.25)	(0.125)	(0.0625)	0	0	(1)
13-bit format	(T4)	(T3)	(T2)	(T1)	(T0)	(0)	(0)	(1)

Config, Configuration Setup register

- Register Address: 0x01
- Register Attribution: Read/Write
- Default Data: 0x00 for 1st Byte, 0x20 for 2nd Byte after POR. If user used only 1-Byte, it is ok to read/write 1-Byte command via digital interface; the only 1st Byte (MSB) will be accessed.

BIT	7	6	5	4	3	2	1	0
1 st Byte	OS	CR1	CR0	F1	F0	POL	ALTM	SD
	0	0	0	0	0	0	0	0
2 nd Byte	Reserved		AL	EM	Reserved			
	0	0	1	0	0	0	0	0

OS, One shot Conversion bit

When the device is in shutdown mode, setting this bit as '1' will trigger a single time temperature conversion. During the conversion, the OS bit reads as '0'. The device returns to shutdown mode once it completes the single conversion. This feature is used for reducing power consumption when continuous temperature monitoring is not necessary.

CR1, CR0, Conversion Rate Selection bits

These 2 bits allow user to setup different conversion rate for temperature. The default is 00 after POR, meaning the conversion rate is 8Hz, i.e. 8 times conversion every second.

CR1	CR0	Conversion Rate / Conversion Time
0	0	8.0Hz / 0.125s (default)
0	1	4.0Hz / 0.25s
1	0	1.0Hz / 1.0s
1	1	0.25Hz / 4.0s

F1, F0, Fault Queue bits

These 2 bits are used to setup the number of fault conditions to trigger alert. The default is 00 after POR, which means one time fault. This feature is used to prevent a false alert, which is immune to certain noise in application.

F1	F0	Fault Queue Number
0	0	1 (default)
0	1	2
1	0	4
1	1	6

POL, Alert Output Polarity bit

This bit allows user to setup the polarity of ALERT pin for output. The default is 0 after POR, meaning ALERT pin is active low. When POL bit is set as '1', the ALERT pin becomes active high and the state of ALERT pin is inverted.

ALTM, Alert Operation Mode bit

This bit allows user to select ALERT pin operation mode: Comparator Mode or Interrupt Mode. The default is 0 after POR to select Comparator Mode. For detail information, see ALERT output section.

SD, Shutdown bit

This bit allows user to shut down the chip and to make the chip enter into standby mode once writing '1'. The default value is '0', which sets the chip to be in Normal working mode. During shutdown mode, the temperature data is kept as those of last time, no anymore update, and all function blocks are turned-off except interface. Set this bit as '0' can allow the chip be out of shutdown mode. In shutdown mode, the operation current is about 1.0 μ A in typical.

EM, Extended Mode bit

This bit allows user to select 12-bit (EM = 0) or 13-bit (EM = 1) temperature data. When EM bit is set as '1', the temperature resolution is still 0.0625°C resolution. However, the expression range is extended from -255 to +255.

AL, Alert Status bit

The AL bit indicates the Alert status with read-only attribution. In addition, this bit is always read as the inversion of POL bit. When the POL bit equals 0, the AL bit reads as 1 until the measured temperature equals or exceeds Temperature (HIGH) for the programmed number of consecutive faults, causing the AL bit to read as 0. The AL bit continues to read as 0 until the temperature falls below Temperature (LOW) for the programmed number of consecutive faults, when it again reads as 1. Vice versa, when the POL bit is '1', the AL bit reads as 0 until the temperature equals or exceeds Temperature (HIGH). And the AL bit is set as 0 again once the temperature falls below Temperature (LOW). The status of the TM bit does not affect the status of the AL bit.

Low_Temp_Set, Setup Low Temperature Limitation register

- Register Address: 0x02
- Register Attribution: Read/Write
- Default Data: 0x4B (1st Byte) 0x00 (2nd Byte) after POR

BIT	BIT	7	6	5	4	3	2	1	0
1 st Byte	12-bit	L11	L10	L9	L8	L7	L6	L5	L4
	13-bit	(L12)	(L11)	(L10)	(L9)	(L8)	(L7)	(L6)	(L5)
	Default	0	1	0	0	1	0	1	1
2 nd Byte	12-bit	L3	L2	L1	L0	0	0	0	0
	13-bit	(L4)	(L3)	(L2)	(L1)	(L0)	(0)	(0)	(0)
	Default	0	0	0	0	0	0	0	0

The high-/low- limit temperature data is determined by High_Temp_Set register [0x03] and Low_Temp_Set register [0x02] with same format as Temp_Data register [0x00], which could be in 12-bit or 13-bit binary format. The chip compares Temp_Data [0x00] register and High_Temp_Set register [0x03]/ Low_Temp_Set register [0x02] in each conversion cycle, which will affect ALT pin output. The default value is 0x4B00 with 12-bit binary format, which means 75°C. For other low-limit temperature data chip, please contact our sales.

High_Temp_Set, Setup High Temperature Limitation register

- Register Address: 0x03
- Register Attribution: Read/Write
- Default Data: 0x50 (1st Byte) 0x00 (2nd Byte) after POR

BIT	BIT	7	6	5	4	3	2	1	0
1 st Byte	12-bit	H11	H10	H9	H8	H7	H6	H5	H4
	13-bit	(H12)	(H11)	(H10)	(H9)	(H8)	(H7)	(H6)	(H5)
	Default	0	1	0	1	0	0	0	0

2 nd Byte	12-bit	H3	H2	H1	H0	0	0	0	0
	13-bit	(H4)	(H3)	(H2)	(H1)	(H0)	(0)	(0)	(0)
	Default	0	0	0	0	0	0	0	0

The high-/low- limit temperature data is determined by High_Temp_Set register [0x03] and Low_Temp_Set register [0x02] with same format as Temp_Data register [0x00], which could be in 12-bit or 13-bit binary format. The chip compares Temp_Data [0x00] register and High_Temp_Set register [0x03] / Low_Temp_Set register [0x02] in each conversion cycle, which will affect ALT pin output. The default value is 0x5000 with 12-bit binary format, which means 80°C. For other low-limit temperature data chip, please contact our sales.

SMBus Digital Interface

Slave Address

The SMBus or I²C slave address of this device can be configured 32 different addresses by setting [A2], [A1] and [A0] pin. See below table for detail, which permit connecting total 32 devices in one SMBus.

No.	A2	A1	A0	R/W	Slave Address in Hex [R/W]
1	GND	GND	GND	1/0	0x91/0x90
2	GND	GND	VCC	1/0	0x93/0x92
3	GND	VCC	GND	1/0	0x95/0x94
4	GND	VCC	VCC	1/0	0x97/0x96
5	VCC	GND	GND	1/0	0x99/0x98
6	VCC	GND	VCC	1/0	0x9B/0x9A
7	VCC	VCC	GND	1/0	0x9D/0x9C
8	VCC	VCC	VCC	1/0	0x9F/0x9E
9	GND	GND	SDA	1/0	0x81/0x80
10	GND	GND	SCL	1/0	0x83/0x82
11	GND	VCC	SDA	1/0	0x85/0x84
12	GND	VCC	SCL	1/0	0x87/0x86
13	VCC	GND	SDA	1/0	0x89/0x88
14	VCC	GND	SCL	1/0	0x8B/0x8A
15	VCC	VCC	SDA	1/0	0x8D/0x8C
16	VCC	VCC	SCL	1/0	0x8F/0x8E
17	GND	SDA	SDA	1/0	0xA1/0xA0
18	GND	SDA	SCL	1/0	0xA3/0xA2
19	GND	SCL	SDA	1/0	0xA5/0xA4
20	GND	SCL	SCL	1/0	0xA7/0xA6
21	VCC	SDA	SDA	1/0	0xA9/0xA8
22	VCC	SDA	SCL	1/0	0xAB/0xAA
23	VCC	SCL	SDA	1/0	0xAD/0xAC
24	VCC	SCL	SCL	1/0	0xAF/0xAE
25	GND	SDA	GND	1/0	0xB1/0xB0
26	GND	SDA	VCC	1/0	0xB3/0xB2
27	GND	SCL	GND	1/0	0xB5/0xB4
28	GND	SCL	VCC	1/0	0xB7/0xB6
29	VCC	SDA	GND	1/0	0xB9/0xB8
30	VCC	SDA	VCC	1/0	0xBB/0xBA
31	VCC	SCL	GND	1/0	0xBD/0xBC
32	VCC	SCL	VCC	1/0	0xBF/0xBE

Timeout

The chip supports SMBus timeout. If the data (SDA PIN) or clock (SCL PIN) is held low for longer than 30 ms (Typ.), the chip will reset its SMBus protocol and be ready for a new transmission.

SMBus Protocol

The chip supports four standard SMBus protocols Send Byte, Read Byte, Write Byte and Receive Byte, shown as below tables.

Write Byte

S	Slave Add	R/W	ACK	Reg Add	ACK	Reg Data	ACK	P
	0x80 to 0xBE	0	0	0x00 to 0x03	0	XXh	0	

Read Byte

S	Slave Add	R/W	ACK	Reg Add	ACK	S	Slave Add	R/W	ACK	Reg Data	NACK	P
	0x80 to 0xBE	0	0	0x00 to 0x03	0		0x80 to 0xBE	1	0	XXh1	1	

Send Byte

S	Slave Add	R/W	ACK	Reg Add	ACK	P
	0x80 to 0xBE	0	0	XXh	0	

Receive Byte

S	Slave Add	R/W	ACK	Reg Add	NACK	P
	0x80 to 0xBE	1	0	XXh	1	

Here S means SMBus Start to communication; P, means communication STOP.

Slave Add, means the chip's slave address.

Reg Add, means pointed register address.

Reg Data, means data to be written into register or read from register.

For this chip, each register includes 2 Bytes, so generally reading or writing operation is based on 1 Word (2-Bytes). Also it is permitted to read 1 byte for read/write, and then the 1st byte will be accessed in first.

Compatible with I²C

The chip is compatible with both SMBus and I²C. The major difference between SMBus and I²C are shown as below. For more information, refer to SMBus specification v2.0 and I²C specification v2.1.

- (1). Besides DC specification difference, this chip supports I²C fast mode (400 kHz) and standard mode (100 kHz), which can cover SMBus maximum frequency 100 kHz. For SMBus protocol, the minimum frequency is 10 kHz. There is no such limitation for I²C.
- (2). For SMBus protocol, the communication will be reset if holding clock or data low with duration over 30ms (Typ.). There is no timeout for I²C.
- (3). ARA (Alert Response Address) general call is only valid interrupt in SMBus, not valid in I²C.

General Call

The PJ85775 device responds to a two-wire general-call address (0000 000) if the eighth bit is 0. The device acknowledges the general-call address and responds to commands in the second byte. If the second byte is 0000 0110, the PJ85775 internal registers are reset to power-up values.

High-Speed (HS) Mode

If the master needs to run at frequencies above 400 kHz in I²C, the master device must issue an HS-mode master code (0000 1xxx) as the first byte after a START condition to switch the bus to high-speed operation. After the HS-mode master code has been issued, the master transmits a slave address to initiate a data-transfer operation. The bus continues to operate in HS-mode until a STOP condition occurs on the bus. Upon receiving the STOP condition, the PJ85775 device will return to fast-mode operation. Below is the example for reading operation in high speed mode.

S	HS-mode code	Slave Add	R/W	ACK	Reg Add	ACK	Sr	Slave Add	R/W	ACK	Reg Data	NACK	P
	0x08 to 0x0F	0x80 to 0xBE	0	0	0x00 to 0x03	0		0x80 to 0xBE	1	0	XXh	1	

ALERT Output

ALERT pin is output with open drain, which can be set active low or active high by setting POL bit. In addition, this pin is triggered when the measured temperature equals or exceeds the high-limitation temperature setup in the registers of High_Temp_Set. There are two types of ALERT output mode: comparator mode and interrupt mode.

Comparator mode (ALTM = 0)

Below Figure shows the mechanism of the ALERT output in comparator mode. In this mode, the ALERT pin will become active if the monitored temperature equals or exceeds the value setup in High_Temp_Set [0x03] register for a consecutive number of faults according to setup by F1 and F0 bits. The ALERT pin keeps active until the temperature falls below the value setup in Low_Temp_Set [0x02] register.

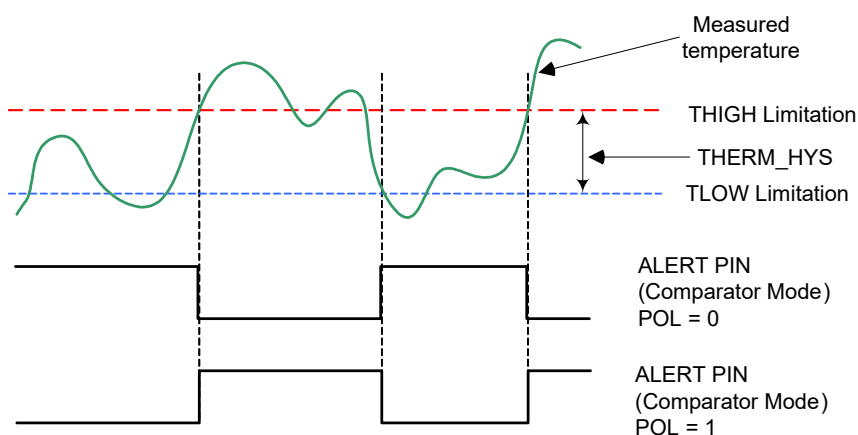

Figure-9. ALERT pin output in comparator mode

Interrupt mode (ALTM = 1)

Below Figure shows the mechanism of the ALERT pin output in interrupt mode. In this mode, the ALERT pin becomes active when the temperature equals or exceeds the value setup in High_Temp_Set [0x03] register for a consecutive number of faults according to setup by F1 and F0 bits. The ALERT pin keeps active until a read operation of any register happens or the chip responds to SMBus Alert Response Address (ARA) successfully.

When ALERT pin is cleared, it will become active again only when the temperature falls below the value setup in Low_Temp_Set [0x02] register, and keeps active until being cleared by reading register or responding to SMBus ARA, ALERT pin is also cleared by setting the chip in shutdown mode.

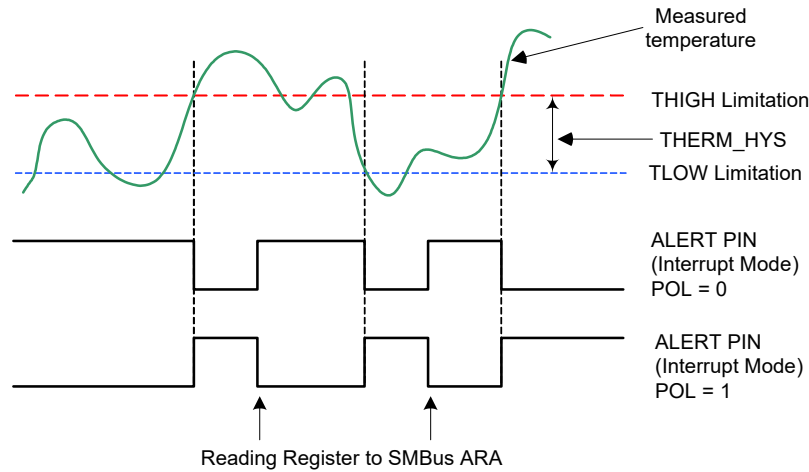

Figure-10. ALERT pin output in interrupt mode

SMBus Alert Response Address (ARA)

The chip supports the SMBus alert function feature. When the chip operates in interrupt mode (ALTM = 1), it can be connected as SMBus alert signal, used as a processor interrupt or as SMBus ALERT. When the master detects that the ALERT pin is asserted, it will send Alert Response Address (ARA) to general address (0001, 1001b). All devices with active interrupts will respond with client address. If the alert pin is active, the device acknowledges the SMBus command by returning the slave address from SDA line. If more devices than one on the bus respond SMBus ARA, arbitration during the slave address portion of SMBus ARA determines which device clears the alert trigger. The device with the highest priority (lowest address) wins the arbitration. If the chip wins the arbitration, ALERT pin is released after completion of SMBus ARA command. If the chip loses the arbitration, it will keep ALERT pin active. See System Management Bus (SMBus) Specification for more detail. Below Figure shows the mechanism of the ALERT output SMBus Alert mode.

S	Slave Add	R/W	ACK	Reg Add	ACK	P
	0001,100	1	0	100x,xxxS	1	

Here Reg Add presented the chip real actual address setup by user. S bit indicates if the alert condition is caused by the temperature exceeding T (HIGH) or falling below T (LOW). The S bit is '1' if the temperature is greater than T (HIGH), or '0' if the temperature is less than T (LOW).

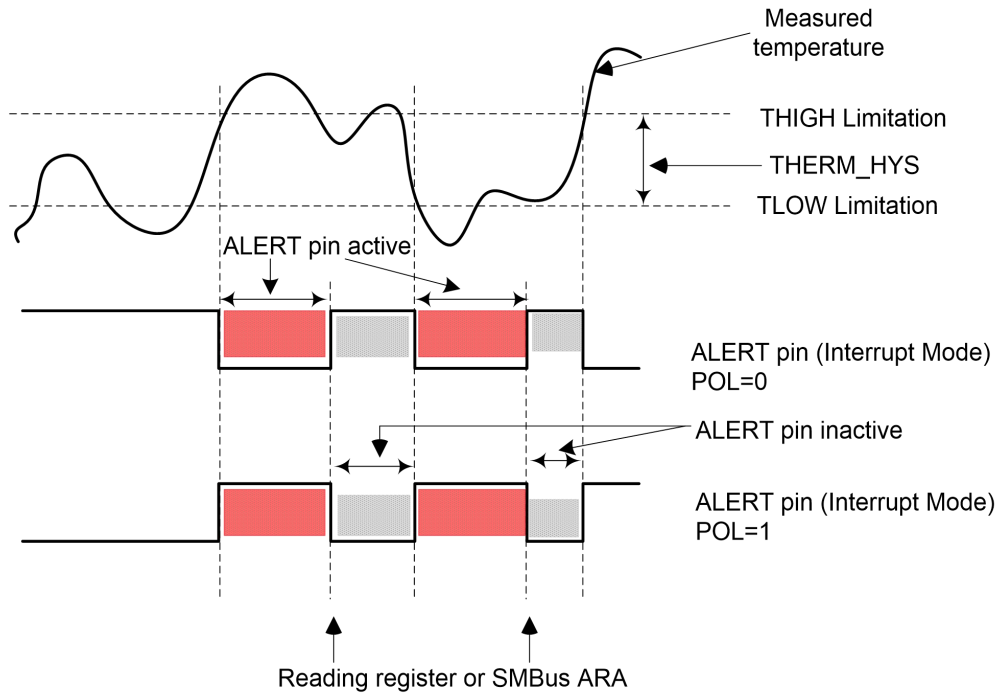

Figure-11. ALERT pin in SMBus Alert Response (ARA)

Applications Information

How to Improve Temperature Accuracy

The temperature measurement of the chip is based on semiconductor physics principle. Forward voltage of diode is a function of temperature. The formula is shown as below.

$$V_F = \frac{kT}{q} \ln\left(\frac{I_F}{I_S}\right)$$

Here,

V_F - forward voltage

I_F - forward current

I_S - reverse saturation current

k - Boltzmann constant

T - Temperature in K

q - Electric charge constant

To cover wide temperature range, i.e. -40°C to 125°C, a very small voltage variation is corresponding to every degree C temperature change. MetaWells has applied many ways to improve measurement accuracy in chip circuits design, such as compensation, trimming etc. In real system design, however, some factors that can increase measurement error need to be considered. Most issues that usually occur are highlighted as below.

Noise between VCC and GND

It is very necessary to place a low ESR ceramic cap (C_{IN}) between VCC and GND pin to filter digital noise, although suppression noise circuit has been built inside the chip. This filter cap should be placed as close as possible to the chip. The recommended capacitance is 0.1 μ F.

Thermal Response Time

It is very necessary to wait enough time for obvious temperature changing of target due to thermal time constant, e.g. food temperature could change from -20°C to 20°C when taken out of refrigerator, which could take over ten minutes to reach thermal equilibrium eventually. Enough time is still needed for the target to reach thermal equilibrium, even forcing temperature transient into target object. For this chip, the temperature step response changing from room temperature to oil bath of 125°C is shown as below. (Based on SOP-8P package)

Room Temperature	Target Temperature	Change ratio	Delta T	Time (s)
26.8°C	125.0°C	63%	61.9°C	2.3
		80%	78.5°C	3.8
		90%	88.4°C	5.6
		100%	98.2°C	20.0

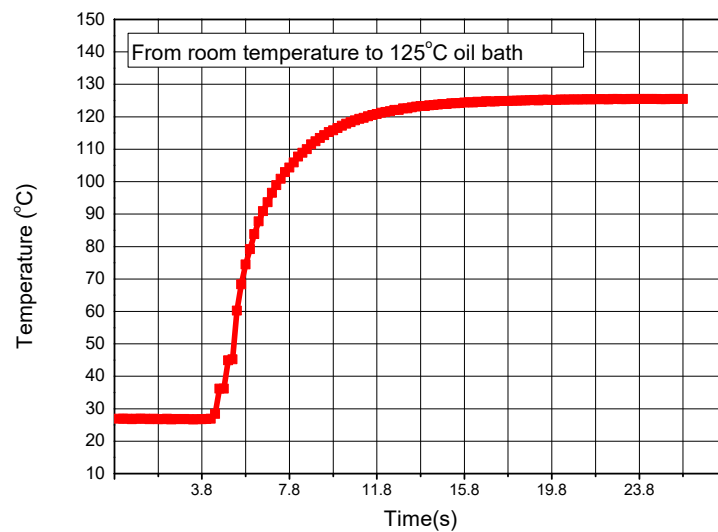

Vice versa, it will take longer time, about 150 s, when the chip temperature is back to room temperature, once taking the chip out of oil bath of 125°C. See below plot.

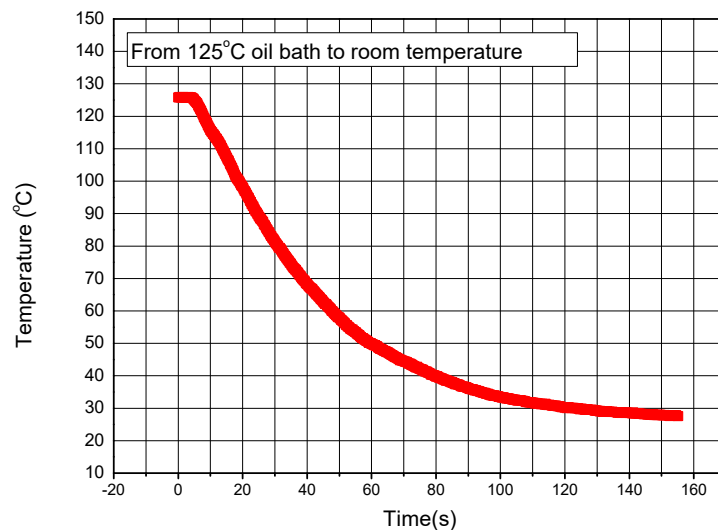

PCB Layout

Cautions below are important to improve temperature measurement in PCB layout design.

Device placement

It is better to place the chip away from any thermal source (e.g. power device in board), high speed digital bus (e.g. memory bus), coil device (e.g. inductors) and wireless antenna (e.g. Bluetooth, WiFi, and RF). It is recommended to place the chip close to the remote diode.

C_{IN}, Pull-up resistor

It is better to place C_{IN} as close as possible to VCC and GND pins of the chip. The recommended C_{IN} value is 0.1 uF with low ESR ceramic cap although using multi caps, such as 1.0 uF plus 0.1 uF or 0.01 uF, is ok, which can suppress digital noise with different frequency range.

User has to put a pull-up resistor with 4.7 kΩ to 10 kΩ for SDA and SCL pins respectively. It is ok to use smaller resistors such as 2 kΩ to 3 kΩ in real application, if multi slave devices are used in the same bus.

Standalone Thermostat

PJ85775 can also be used as standalone thermostat shown as below. It does not need external MCU to setup High/Low limitation temperature via SMBus/I²C communication. The trigger temperature and hysteresis temperature can be setup in factory before shipping to customer. For example,

Trigger temperature is 55°C, and Hysteresis temperature is 5°C.

Which means when the chip temperature equals or exceeds 55°C, the ALERT pin will be set low. And once the temperature of the chip drops below 50°C (55 - 5), the ALERT pin will be released back to high (pulled by R_{pu} to VCC).

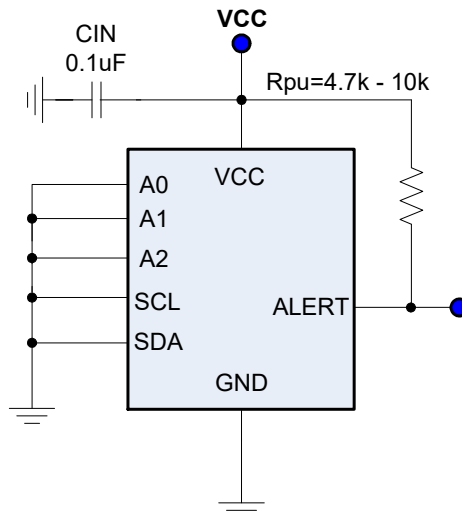

Package Outline Dimension-SOP-8P

SOP-8P Unit (mm)

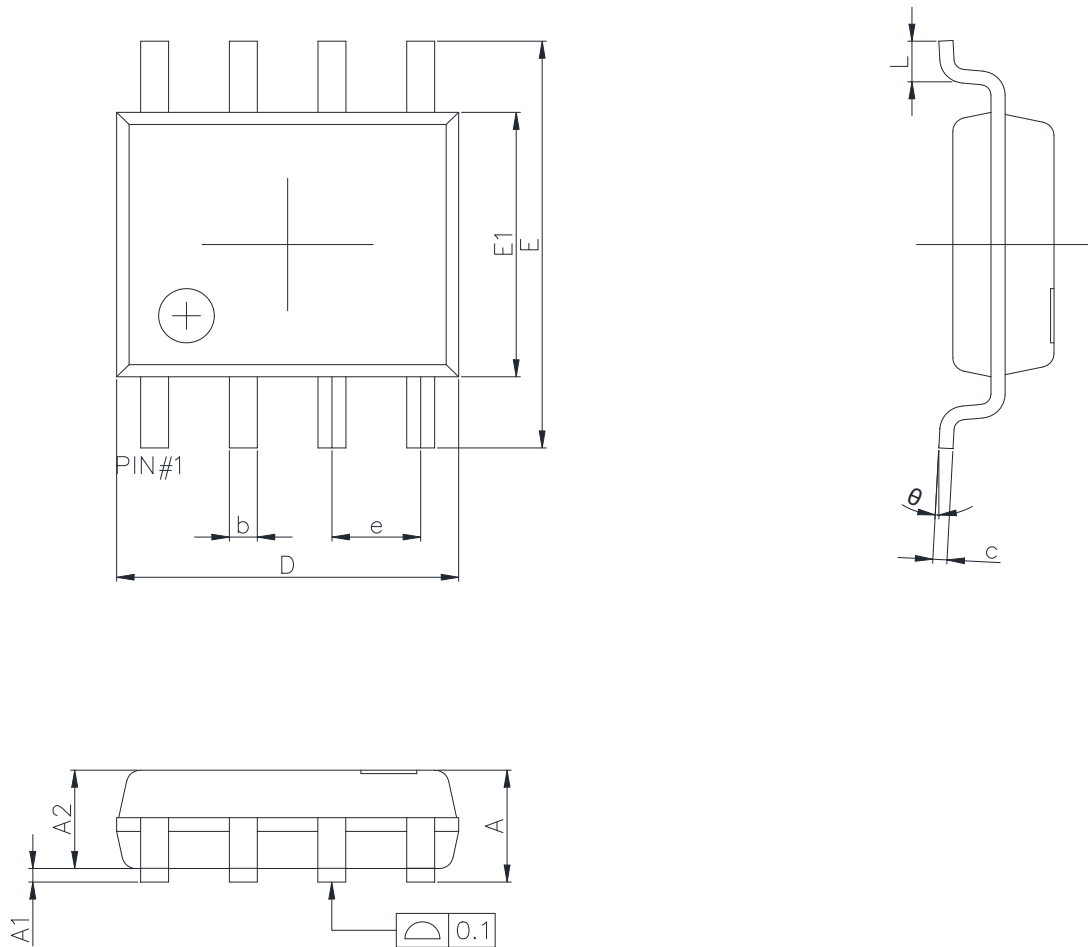

Symbol	Dimensions in Millimeters		Dimensions in Inches	
	Min.	Max.	Min.	Max.
A	1.350	1.750	0.053	0.069
A1	0.100	0.250	0.004	0.010
A2	1.250	1.650	0.049	0.065
b	0.33	0.51	0.013	0.020
C	0.17	0.25	0.007	0.010
D	4.700	5.100	0.185	0.201
E	5.800	6.200	0.228	0.244
E1	3.700	4.100	0.146	0.161
e	1.270(BSC)		0.050(BSC)	
L	0.400	1.270	0.016	0.050
θ	0°	8°	0°	8°

Recommend Land Pattern Layout-SOP-8P

SOP-8P Unit (mm)

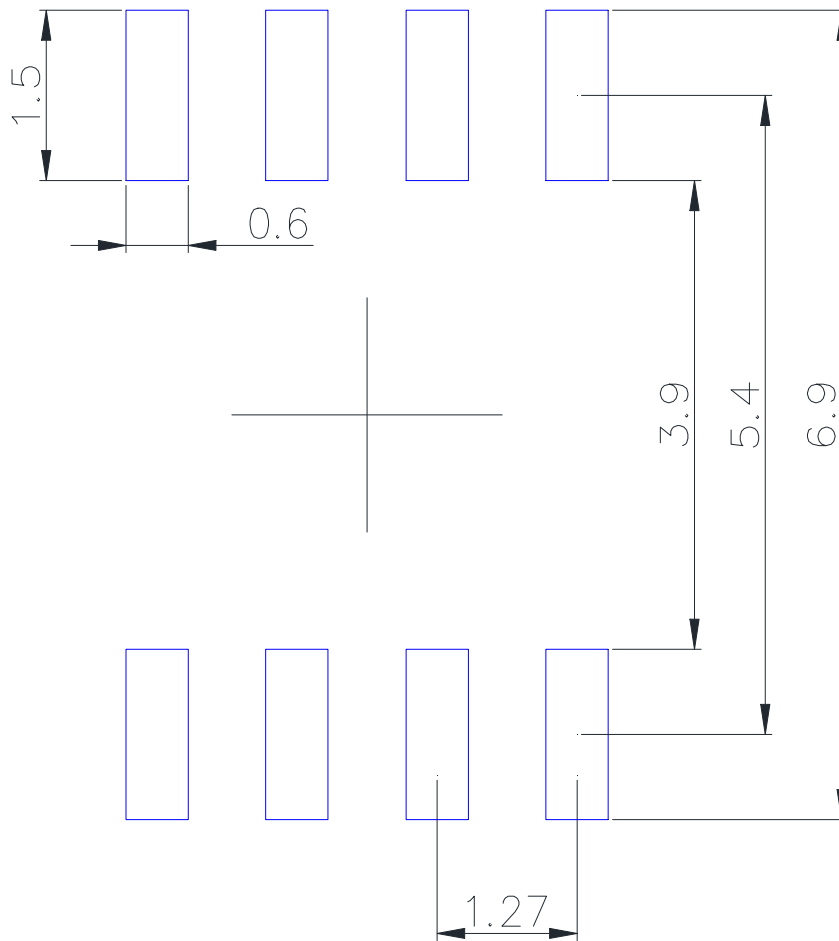

Note:

- (1) All dimensions are in millimeter.
- (2) Recommend tolerance is within ± 0.1 mm.

Package Outline Dimension-MSOP-8P

MSOP-8P Unit (mm)

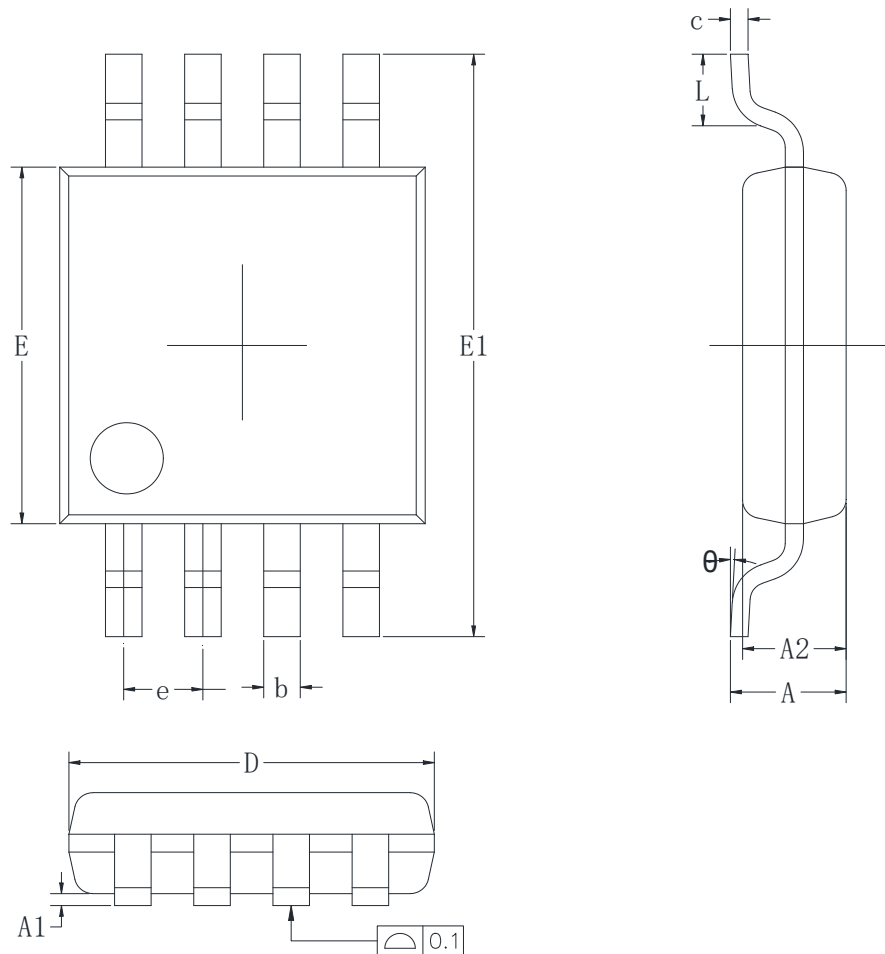

Symbol	Dimensions in Millimeters		Dimensions in Inches	
	Min.	Max.	Min.	Max.
A	0.820	1.100	0.032	0.043
A1	0.020	0.150	0.001	0.006
A2	0.750	0.950	0.030	0.037
b	0.250	0.380	0.010	0.015
C	0.090	0.250	0.004	0.010
D	2.900	3.100	0.114	0.122
E	2.900	3.100	0.114	0.122
E1	4.700	5.100	0.185	0.201
e	0.650(BSC)		0.026(BSC)	
L	0.400	0.800	0.016	0.031
theta	0°	8°	0°	8°

Recommend Land Pattern Layout-MSOP-8P

MSOP-8P Unit (mm)

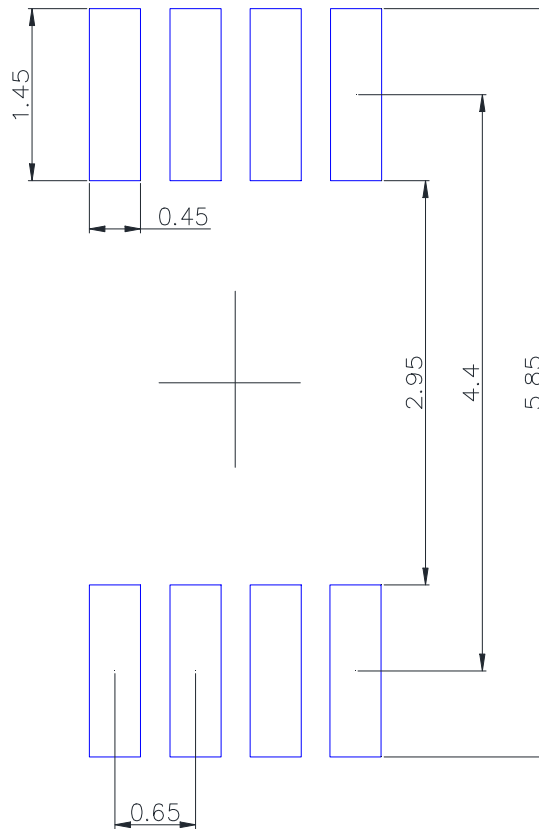

Note:

- (1) All dimensions are in millimeter.
- (2) Recommend tolerance is within ± 0.1 mm.

Version History

Version	Date	Changes
Rev.1.0	2025-11-21	Initial release

Disclaimer

MetaWells Co., Ltd. and all other MetaWells Co., Ltd. trademarks are the exclusive property of MetaWells Co., Ltd.. Any mention of additional trademarks or registered trademarks in this document is made in acknowledgment of their respective owners.

Without the consent of MetaWells Co., Ltd. , any modification to any part or subsection of the company's product specifications and datasheets is strictly prohibited in any form or manner. MetaWells Co., Ltd. reserves the rights to make changes of the content herein the document follow PCN procedure. Please refer to our website for latest document. It is recommended that customers obtain the latest version of relevant information and verify its timeliness and completeness before placing an order. All products are sold in accordance with the terms and conditions provided in the sales contract at the time of order confirmation, which includes warranty scope, intellectual property rights, and liability limitations.

During the sales period, MetaWells Co., Ltd. guarantees that the performance of the products will be in accordance with the company's standard warranty. The company utilizes testing and other quality control techniques to ensure the necessity to maintain this warranty. Except for government-mandated requirements, there is no need for special testing of measurement tables or other instruments.

Customers must acknowledge that our products are not intended or manufactured for use in life support systems or other high-risk activities or environments. The utilization of our products in such applications may lead to severe consequences, including personal injury, loss of life, property damage, or environmental harm. Our products are explicitly not warranted for deployment in high-risk activities, and we shall bear no responsibility towards customers or third parties for such usage.

MetaWells Co., Ltd. commits to providing technical support, assistance, advice, and information, in line with our current capabilities, including guidance related to the design, development, or debugging of purchased boards or other applications. However, we hereby disclaim all warranties concerning technical support, merchantability, or fitness for a particular purpose. We do not guarantee the error-free operation of boards or applications in conjunction with our support services, and we shall not be held liable for any consequences arising from the utilization of our support services.

Copyright© MetaWells Co., Ltd. 2024

Website : www.MetaWells.com